



SUPERSUCKER® **INDUSTRIAL VACUUM LOADER**



OPERATORS MANUAL

Table of Contents

1 Safety

General Safety Instructions and Practices	1-1
Visual Attention Safety	1-2
Personal Protection Equipment (PPE)	1-3
When Using Pressurized Air or Water	1-4
General Hazards and Prevention Safety	1-5
Visibility Conditions When Operating	1-6
Mounting and Dismounting Truck or Equipment	1-6
Hot Surface	1-6
Safety Signs	1-6
Equipment Guards	1-6
Crushing Hazards and Prevention Safety	1-7
Debris Body Prop Support	1-7
Tailgate Prop Support	1-7
Truck Tip Over	1-7
Trip and Fall Prevention Safety	1-8
High-Pressure Fluid Leak Hazards	1-9
Power Lines/Static Electrical Hazard Warnings	1-10
Overhead Power Line Tips for Construction Workers Before You Begin Construction Work ..	1-10
Working with Tools and Equipment	1-10
Chemical and Biological Hazard Safety	1-11
Chemicals and Diesel Engine Exhaust	1-11
Sewer Gas Hazard	1-11
Chemical Waste Hazard	1-11
Biological Hazards	1-11
Dust Hazard	1-11
Transport Safety and Hazards Warnings	1-12
Before Transporting Truck Inspection	1-12
Never Exceed your Gross Vehicle Weight Rating (GVWR)	1-12
Pedestrian Safety	1-12
Determine Stopping Characteristics of Truck for Transporting Braking Tests	1-13
Determine Maximum Turning Speed Before Operating on Roads or Uneven Ground	1-13
When Transporting Equipment	1-13
Job Site Safety and Hazard Warnings	1-14
To Help Avoid Injury	1-14
Arrange for Traffic Control	1-14
Prepare for Working Near Existing Utilities	1-14
Plan for Emergency Services	1-14
Inspect the Job Site	1-15
Visibility Conditions When Operating	1-15
Prepare the Job Site	1-15

Vacuum Equipment Operation Safety and Hazard Warnings	1-16
Emergency Stop Button Function	1-16
Vacuum Operation Safety	1-17
Pre-Start Checklist	1-18
Vacuum Operation	1-18
Vacuum Relief Valve Safety	1-19
Vacuum Relief Valves	1-19
Operating the T-Type Vacuum Relief Valve	1-19
Testing the T-Type Vacuum Relief Valve	1-20
Operating the Remote-Operated Vacuum Relief Valve	1-21
Testing the Remote-Operated Vacuum Relief Valve	1-22
High-Pressure Water Safety and Hazard Warnings	1-23
Dust Hazard and Explosion Prevention Safety	1-24
Hydrocarbon Waste Recovery	1-25
Controlling Lower Explosive Level (LEL)	1-26
High-Temperature Prevention	1-26
Static Charge Dissipation	1-27
Spark and Fire Prevention Safety	1-28
Debris Body Dumping Safety and Hazard Warnings	1-29
Sewer Gas Safety and Hazard Warnings	1-30
Confined Space Hazard	1-30
Trenching Hazards	1-31
De-energize and Lockout Procedures	1-32
Hazards With Equipment Maintenance	1-33
Before Performing Service, Repairs, and Maintenance on the Equipment	1-33
Performing Service, Repairs, Lubrication, and Maintenance	1-33
Safety Shields, Guards, and Safety Devices Inspection	1-33
Decal Location	1-34
Decals	1-41
Preparation Before Traveling To Worksite	1-48

2 Pre-Operation

Introduction	2-1
Principles of Operation	2-1
Equipment Specifications	2-1
Vacuum System	2-3
Pure Vacuum	2-3
Air Conveyance	2-3

Airflow	2-4
Rotary Lobe Vacuum Pump Operation	2-5
Liquid Ring Vacuum Pump Operation	2-6
Liquid Ring Error Light	2-8
Cooling Air Injection Valve	2-8
Seal Water Contamination	2-8
Vacuum Relief Valves	2-9
Suction Line Connections	2-10
Loading Rates	2-11

3 Control System Operation

Control Panel	3-1
Bag Pulsing	3-1
Transfer Case Shifter Control	3-2
Control Valves	3-2
Dumping Payload	3-3
Body Prop Support	3-4
Tailgate Prop	3-4
Over The Road Operation	3-4
Electric Vibrator	3-5
Operation of Vibrator	3-5
Boom Operation (Optional)	3-5
Water System (Optional)	3-6
Sludge Pump (Optional)	3-7
Operation of Sludge Pump	3-7
Mobile Ground Verification (MGV) System (Optional)	3-8
Liquid Ring Control Panel (Optional)	3-9
High Dump Operation (Optional)	3-10

4 Lubrication and Maintenance

General Information	4-1
Preventive Maintenance Instructions	4-1
Lubrication Recommendation Chart	4-1
Maintenance Schedule	4-2
Maintenance Items	4-3
Liquid Ring Vacuum Pump Oil	4-5
Liquid Ring Vacuum Pump Intercooler Screens	4-5
Liquid Ring Transfer Case Oil Strainer	4-5

5 Troubleshooting

Troubleshooting Overview	5-1
The Basic Troubleshooting Process	5-1
Mechanical Troubleshooting	5-2

Electrical Vibrator Troubleshooting	5-6
Schematic Supersucker Hydraulic System - 0035447	5-7
Schematic Supersucker Liquid Ring Water System - 0042508	5-8
Schematic SS Liquid Ring Transfer Case Hydraulic - 0042518	5-9

6 Service and Spare Parts

7 Index

General Safety Instructions and Practices

A careful operator is the best operator. Safety is of primary importance to the manufacturer and should be to the owner/operator. Most accidents can be avoided by being aware of your equipment, your surroundings, and observing certain precautions. The first section of this manual includes a list of Safety Messages that, if followed, will help protect the operator and bystanders from injury or death. Read and understand these safety messages before assembling, operating, or servicing this equipment. This equipment should only be operated by those persons who have read the manual, who are responsible and trained, and who know how to do so responsibly.



The Safety Alert Symbol combined with a Signal Word, as seen below, is used throughout this manual and on decals which are attached to the equipment. The Safety Alert Symbol means: **“ATTENTION! BECOME ALERT! YOUR SAFETY IS INVOLVED!”** The Symbol and Signal Word are intended to warn the owner/operator of impending hazards and the degree of possible injury faced when operating this equipment.

Practice all usual and customary safe working precautions and above all remember safety is up to **you**. Only **you** can prevent serious injury or death from unsafe practices.



DANGER

Indicates an imminently hazardous situation which, if not avoided, **WILL** result in death or serious injury.



WARNING

Indicates a potentially hazardous situation which, if not avoided, **COULD** result in death or serious injury.



CAUTION

Indicates a potentially hazardous situation which, if not avoided, **MAY** result in minor or moderate injury and property damage. It may also be used to alert against unsafe practices.

NOTICE

Indicates a potentially hazardous situation which, if not avoided, **MAY** result in property damage. It may also be used to alert against unsafe practices.

NOTE

Identifies points of particular interest for more efficient and convenient operation or repair.



READ, UNDERSTAND, and FOLLOW the following **Safety Messages**. Serious injury or death may occur unless care is taken to follow the warnings and instructions stated in this manual and in the Safety Messages on the implement. Always follow the instruction in this manual and use common sense to avoid hazards.

Visual Attention Safety

Pictographs are used throughout this manual to help bring your visual attention to safety issues.

1



SAFETY HAZARD	SAFETY AVOIDANCE	SAFETY PREVENTION
<p>Pictograph surrounded by a triangle indicates a Safety Hazard that must be avoided.</p> <p>Example:</p>  <p>Equipment contacting overhead electrical lines</p>	<p>Pictograph in a circle or inside a box indicates an avoidance procedure that should be followed to prevent injuries.</p> <p>Example:</p>  <p>Always shut off engine and remove key before working on equipment.</p>	<p>A circle with a slash through it indicates an action that is prohibited.</p> <p>Example:</p>  <p>No Smoking</p>

Figure 1-1

NOTE

If you want a translation of this safety section in Spanish or French, please contact:

Translation — Safety Section
130 W Boxhorn Drive
Mukwonago, WI 53149
(800) 837-9711

Personal Protection Equipment (PPE)

					
Wear Safety Glasses to Comply with ANSI Z87	Wear Hard Hat	Wear Safety Shoes	Wear Hearing Protection	Wear Protective Gloves	Wear Safety Reflective Vest

Figure 1-2

Always wear protective clothing and personal safety devices issued to you or required by job conditions.

This should always include:

- Hard hat
- Safety shoes
- Safety glasses with side shields (marked to comply with ANSI Z87), goggles, or face shield
- Heavy gloves (chemical resistant)
- Hearing protection
- Reflective clothing



WARNING

Never wear loose clothing or jewelry that can catch on controls or other parts of the machine. Loose clothing can be drawn into the suction hose. Never wear a wristwatch or finger rings when working on or around equipment.

When Using Pressurized Air or Water

			
<p>Wear Face Protection Shield</p>	<p>Wear Wet Weather Protective Suit</p>	<p>Wear Waterproof Gloves and Safety Shoes with Metatarsal</p>	<p>Wear Respirator</p>

Figure 1-3

When using pressurized air or water for cleaning or material erosion/movement, you should use the following:

- Face Shield
- Wet Weather Protective Suit
- Waterproof Gloves
- Respirator
- Safety Boots with Metatarsal Guard

General Hazards and Prevention Safety





				
Read and Understand Operator's Manual	DO NOT USE DRUGS or ALCOHOL before or while operating equipment	Always shut off engine and remove key before working on equipment	Always install Debris Body and tail gate props before working under equipment	Always wear your seatbelt

Figure 1-4

WARNING

To avoid serious injury or death, do the following:

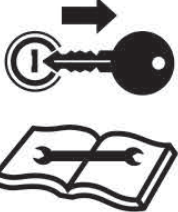
- **Read, understand, and follow** the operator's manual instructions, warnings, and safety messages.
- **Do not allow** untrained or unauthorized persons to operate equipment.
- **Do not allow** untrained coworkers to operate or assist in operating equipment.
- **Do not allow** bystanders near equipment or work area.
- **Do not allow** anyone to operate equipment while under the influence of drugs or alcohol.
- **Do not use drugs or alcohol** before or while operating equipment.
- **Consult** medical professional for medication impairment side effects.
- **Wear** appropriate safety personal protective equipment (**PPE**).
- **Wear** appropriate breathing respirator and protective suit when operating with hazardous or unknown substances.
- **Do not wear** loose clothing or jewelry to avoid injury from entanglement in rotating parts.
- **Keep body and limbs away** from suction inlets.
- **Do not open or close** the tailgate or raise or lower the body unless the area is clear of people and obstructions.
- **Never** put any part of your body under an open tailgate unless it is sufficiently propped.
- **Never operate** the vacuum pump unless you are certain the suction hose is clear of people and obstructions.
- **Never operate** the vacuum pump without the safety relief systems working properly as described within this manual.
- **Do not enter the debris body** if hazardous materials are suspected inside the debris body. Take the unit to a certified tank cleaning facility.
- **Always shut off the engine**, remove the key, and set the parking brake before working on the truck or equipment.
- **Stay alert.** Prolonged operation can cause fatigue. **Stop and rest.**

General Hazards and Prevention Safety — continued





			
<p>Use adequate lighting for proper vision.</p>	<p>Do not touch hot surface. Keep hands and limbs away from hot surfaces.</p>	<p>Tanks can be under pressure. Relieve pressure before opening.</p>	<p>Use three-point contact when climbing on equipment.</p>

Figure 1-5

Visibility Conditions When Operating

- **Operate in daylight** or with lights that gives at least 50 yards clear visibility.
- **Be able to see** and identify passersby, steep slopes, ditches, drop-offs, overhead obstructions, power lines, debris, and foreign objects.
- **Use extreme care** when backing up. Vision may be limited. Severe damage or injury can occur.
- **Do not run engines** in enclosed building without adequate exhaust ventilation.

Mounting and Dismounting Truck or Equipment

- **Only** mount or dismount when truck and moving parts are stopped.
- **Always use three-point contact** when climbing on or dismounting equipment.
- **Walkways, steps, and handrails** should be checked before use to ensure a proper non-slip surface. Replace or repair damaged component immediately.

Hot Surface

- **Stay clear** of hot surfaces such as mufflers, hydraulic pumps, valves, and tanks.
- **Relieve pressure** from tank, reservoirs, valves, and hoses before servicing or opening.

Safety Signs

- **Replace** missing, damaged, or unreadable safety signs immediately!

Equipment Guards

- **Never** operate machine if equipment guards are damaged or missing.
- **Replace** missing or damaged guards immediately!

Crushing Hazards and Prevention Safety





				
Never go under raised Debris Body until prop is installed	Never go under raised tailgate until prop is installed	Truck can tip over while dumping debris on un-level surface	Slow down on curves, High Center of Gravity	Truck can tip over when truck wheels are on unstable soil

Figure 1-6

Debris Body Prop Support



WARNING

Never go under raised debris body until prop is installed. Failure to do so could result in personal injury or death.

1. Raise body sufficiently to allow body prop support to be swung into position.
2. Swing body prop support into support position.
3. Slowly lower body until body contacts body prop support.
 - To remove body prop support, reverse above procedure.

Tailgate Prop Support



WARNING

Always position tailgate prop in proper position before entering any areas beneath tailgate or entering body. Failure to do so could result in serious injury or death.

1. Raise tailgate sufficiently to allow tailgate prop support to be swung into position.
2. Swing prop support into support position.
3. Slowly lower body tailgate until tailgate contacts tailgate prop support.
 - To remove tailgate body prop support, reverse above procedure.

Truck Tip Over



WARNING

Always wear seat belt while seated in truck to prevent injury.

- Truck driver must have valid and appropriate training license before transporting liquids on public roads.
- Slow down on curves to prevent truck from tipping over.
- Always ensure unit is on firm and level ground before operating the dump system. When dumping, raise the body in steps, allowing the material to dump out in a steady flow.
- **Do not allow** people and/or vehicles beside debris body while dumping.
- Never drive truck with raised debris body.
- Keep truck away from drop-offs and soft soil shoulder where truck could tip over.

Trip and Fall Prevention Safety

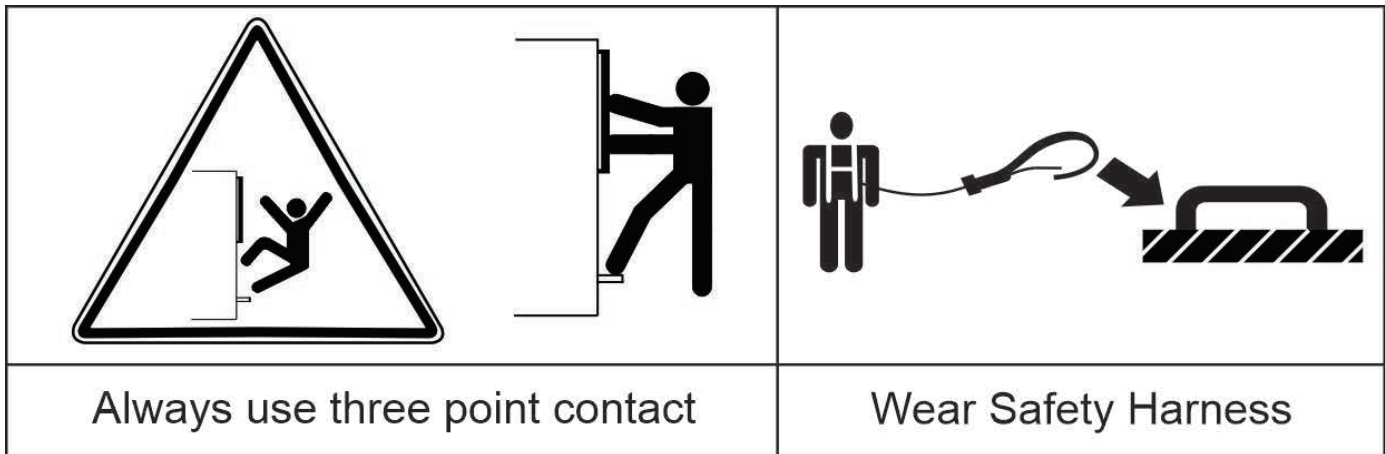

Figure 1-7

- **Always maintain** three-point contact with the machine, using two hands and one foot, or two feet and one hand, at all times during entry and exit. Never grab control levers or steering wheel when mounting or dismounting machine.
- **Walkways and steps** should be checked monthly to ensure a proper non-slip surface. Repair or replace damaged walkway or steps.
- **Keep** grab handles, steps, and walkways free of mud, oil, grease, and other foreign material. Clean non-skid surface material as required.
- **Ground level personnel** must be present whenever climbing onto unit to protect against inadvertent operation.
- **During operation**, occupants on elevated equipment surfaces must wear a full body harness with a lanyard attached to an authorized lanyard anchorage point. Attach only one lanyard per lanyard anchorage point.
- **Face the machine** when entering or leaving the elevated equipment surfaces.
- Only mount or dismount when truck and moving parts have completely stopped.

High-Pressure Fluid Leak Hazards

1

			
High pressure oil penetrating skin.	High pressure oil eroding skin.	Using cardboard to check for oil leaks.	Tank contents under pressure. Allow oil to cool before slowly removing cap.

Figure 1-8

**DANGER**

To avoid serious injury or death from high-pressure hydraulic oil leaks penetrating skin, follow these rules:

- **Do not operate** equipment with oil or fuel leaks.
- **Keep** all hydraulic hoses, lines, and connections **tight** and in **good condition** before applying pressure to the system.
- **Relieve hydraulic pressure** before servicing the hydraulic system.
- **Remove** and replace or test hydraulic hoses if a leak is suspected. Have a qualified service facility perform the test.

**DANGER**

High-pressure fluid leaks can be invisible. When checking for hydraulic leaks and working around hydraulic systems, follow these rules:

- **Always wear** safety glasses with side shields (marked to comply with ANSI Z87) and impenetrable gloves.
- **Use** paper or cardboard to search for leaks.
- **Do not use** hands or body parts to search for leak.
- **Keep** hands and body **away** from pin holes and nozzles ejecting hydraulic fluid.

**CAUTION**

Use caution when removing hydraulic tank cap. Contents may be under pressure.

- Tank contents may be under pressure.
- **Allow oil to cool** before removing cap slowly.
- **Relieve** oil pressure before removing cap slowly.
- **Stay away** from hot oil that may spray from tank or hoses.

**DANGER**

High-pressure hydraulic oil can puncture skin. If injured, seek immediate medical attention and inform the physician of the cause of the injury. Surgery is required to remove the fluid from the body. Failure to seek proper medical attention will result in serious injury or death.



Figure 1-9

Power Lines/Static Electrical Hazard Warnings



Figure 1-10



DANGER

This machine is not insulated and does not provide protection from contact or being near electrical current.

- **Never** operate the unit in an area where overhead power lines, overhead or underground cables, or other power sources may exist without ensuring that the appropriate power or utility company has de-energized the lines.
- **Always** check for power lines before raising boom or debris body.

Follow all requirements for using mobile equipment when working around power lines. The Occupational Safety and Health Administration (OSHA) requirements apply to most workers. The following information is from OSHA. Additional information can be obtained from www.osha.gov.

Overhead Power Line Tips for Construction Workers Before You Begin Construction Work

- Survey the site for overhead power lines.

NOTE

Never get within 10 feet of an overhead power line!

- Consider all overhead lines as energized until the electric utility indicates otherwise or an electrician verifies that the line is not energized and has been grounded.
- In construction work, an overhead power line safety component should be part of your employer's overall safety and health program and safety training.

- If overhead lines are present, call the utility company and ask if the utility company can shut off the lines while you are working near them.
- If overhead lines cannot be shut down, ask the utility company if they can install insulation over the lines during the time you will be working near them.

Working with Tools and Equipment

- If the lines cannot be shut down and/or insulation cannot be applied, a minimum safe distance of 10 feet must be established.
- Only use non-conductive ladders when working on or near overhead power lines.
- Employees shall not be permitted to approach or carry any conductive object closer than 10 feet to an energized line.



WARNING

Electrically insulating coating must be used on water nozzles to prevent electrical contact with underground electrical power lines.

Chemical and Biological Hazard Safety

		
<p>Chemical Burning Skin Hazard</p>	<p>Chemical, Dust and Fumes Inhalation Hazard</p>	<p>Wear Respirator when around hazardous fumes</p>

Figure 1-11

Chemicals and Diesel Engine Exhaust

 **WARNING**

Operating, servicing and maintaining this equipment can expose you to chemicals including gasoline, diesel fuel, lubricants, petroleum products, engine exhaust, carbon monoxide, and phthalates, which are known to the State of California to cause cancer and birth defects or other reproductive harm. To minimize exposure, avoid breathing exhaust, do not idle the engine except as necessary, service your vehicle in a well-ventilated area and wear gloves or wash your hands frequently when servicing your vehicle. Battery posts, terminals and related accessories contain lead and lead compounds, chemicals known to the state of California to cause cancer, birth defects or other reproductive harm. For more information go to www.P65Warnings.ca.gov. This website, operated by California's Office of Environmental Health Hazard Assessment, provides information about these chemicals and how individuals may be exposed to them.

 **WARNING**

Always read carefully and comply fully with the manufacturer's instructions when handling fuels, oils, solvents, cleansers, and any other chemical agent.

Sewer Gas Hazard

- Do not smoke or have lighted materials in or around sewer lines, drains, or catch basins.

Chemical Waste Hazard

- Storm drains, catch basins, and sewers may contain harmful chemicals. To prevent contamination and injury, wear chemical resistant gloves, long sleeves, trousers, and safety glasses or face shields.
- Seek immediate medical attention if exposure or contamination is suspected.

Biological Hazards

- Germs and other biological hazards are common in sewers, drains, and catch basins. Use appropriate personal protective equipment to avoid injury and contamination. Get medical attention for injuries associated with cleaning sewers, drains, and catch basins if biological contamination is suspected.

Dust Hazard

- Repeated or substantial breathing of hazardous dusts, including crystalline silica, could cause fatal or serious respiratory disease including silicosis. Concrete, masonry, many types of rock, and various other materials contain silica sand. California lists repairable crystalline silica as a substance known to cause cancer. Operation of this equipment under certain conditions may generate airborne dust particles that could contain crystalline silica. In those conditions personal protective equipment including an appropriate respirator must be used. If excessive dust is generated, a dust collection or suppression system should also be used during operation.

Transport Safety and Hazards Warnings

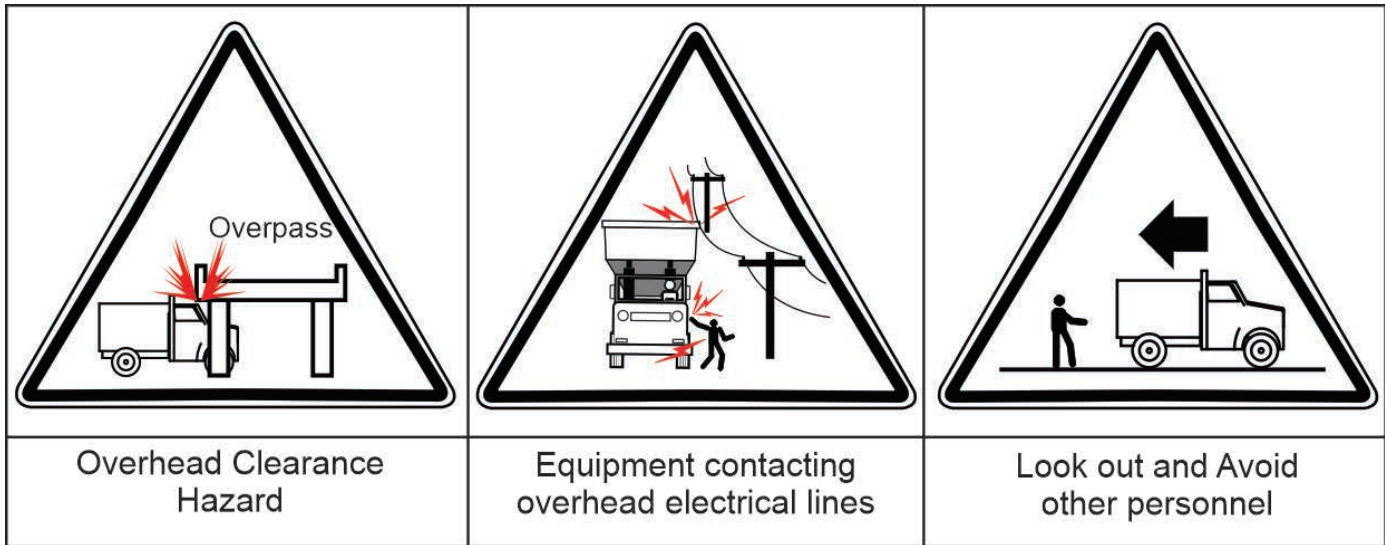

Figure 1-12



WARNING

Follow all steps before moving truck when towing or transporting equipment to avoid serious injury and death:

- Look out for and avoid other personnel, machinery and vehicles in the area. Use a spotter if you **do not** have clear view.

Never Exceed your Gross Vehicle Weight Rating (GVWR)

- In operation on public highways, the combined weight of the chassis, body, and payload must not exceed the gross vehicle weight rating of the chassis as rated by the cab and chassis manufacturer.

NOTE

It is possible to overload the unit capacity.

- Load your water supply at or near the job site.
- Regulate your work to maintain minimum water storage when leaving the work location.

Before Transporting Truck Inspection

- Ensure unit is road worthy by performing a pre-trip inspection before driving to and from job site.
- Check that tailgate is closed and properly locked.
- Ensure all equipment is properly secured and positioned for maximum visibility and adequate clearances.
 - Close all water drain valves and install all plugs and strainers previously removed.
 - Check that boom (if equipped) is locked in transport position and properly secured.
 - Check that all tools, accessories, and work tubes/hoses are properly secured.
 - Check that cabinet doors and access panels are closed.
 - Check that all clean-out doors are closed and latched shut.
 - Check that the dust chute and tailgate are closed and latched shut.
- Always measure overhead clearance height of truck and equipment.
- Check for low hanging electric or telephone wires and power cables on the ground.

Pedestrian Safety

- Conduct a visual check and warning (honk horn) before starting or moving the truck to ensure the safety of people on the ground and other equipment in the area.
- Be aware of all personnel who are working on the ground.
- Look out for and avoid other personnel, machinery and vehicles in the area. Use a spotter if you **do not** have clear view.

Transport Safety and Hazards Warnings — continued

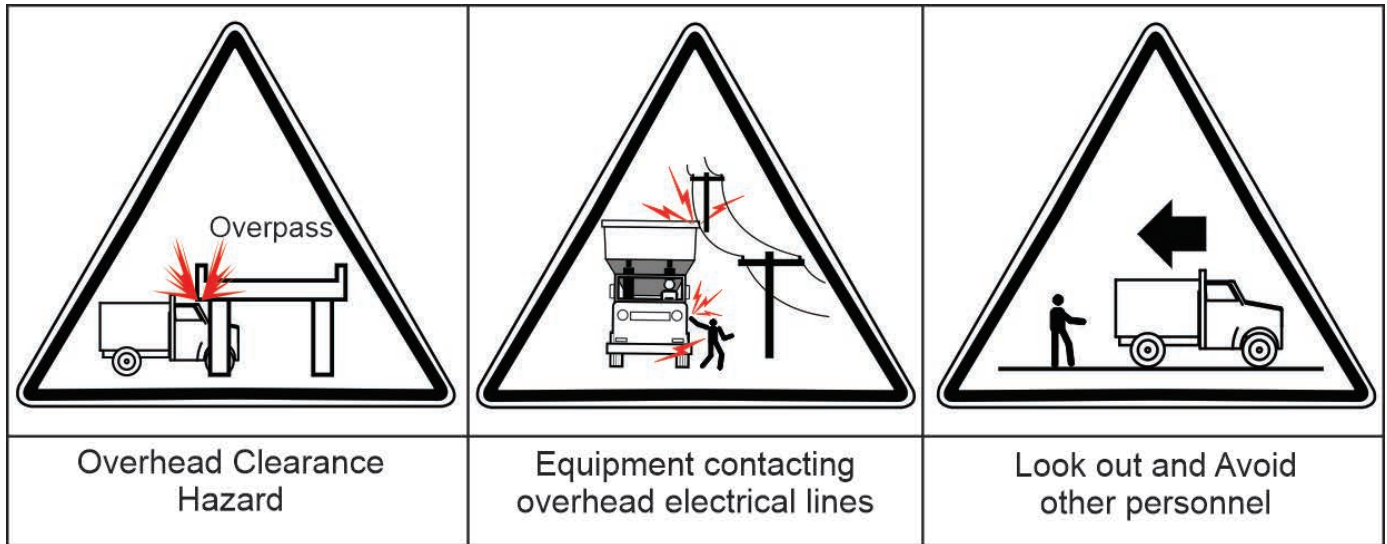

Figure 1-13

Determine Stopping Characteristics of Truck for Transporting Braking Tests

- Stopping distance with loaded debris body will be greater than empty truck.
- Reduce travel speed on wet or icy roads; stopping distances increase.

Determine Maximum Turning Speed Before Operating on Roads or Uneven Ground

- **Test** equipment by slowly increasing speed on turns to determine if it can be operated at higher speeds.
- **Use reduced** turning speeds on sharp turns to avoid equipment turning over.
- Truck has a high center of gravity when carrying a loaded debris body. Use extreme caution when transporting at highway speeds. Slow down for sharp corners to avoid tipping or turning over.

When Transporting Equipment

- **Do not move** truck unless debris body is fully lowered in the horizontal storage position.
- **Always** wear seat belt when operating truck.
- **Follow** all local traffic regulations.

- **Use** low speeds to avoid overturn tipping when debris body is filled.
- **Use** low speeds and gradual steering on curves, hills, rough or uneven surfaces, and wet roads.
- **Turn on** truck flashing warning lights when driving slower than traffic.
- Transport the truck only at safe speeds that allow for proper control of the truck while driving and stopping.

Job Site Safety and Hazard Warnings

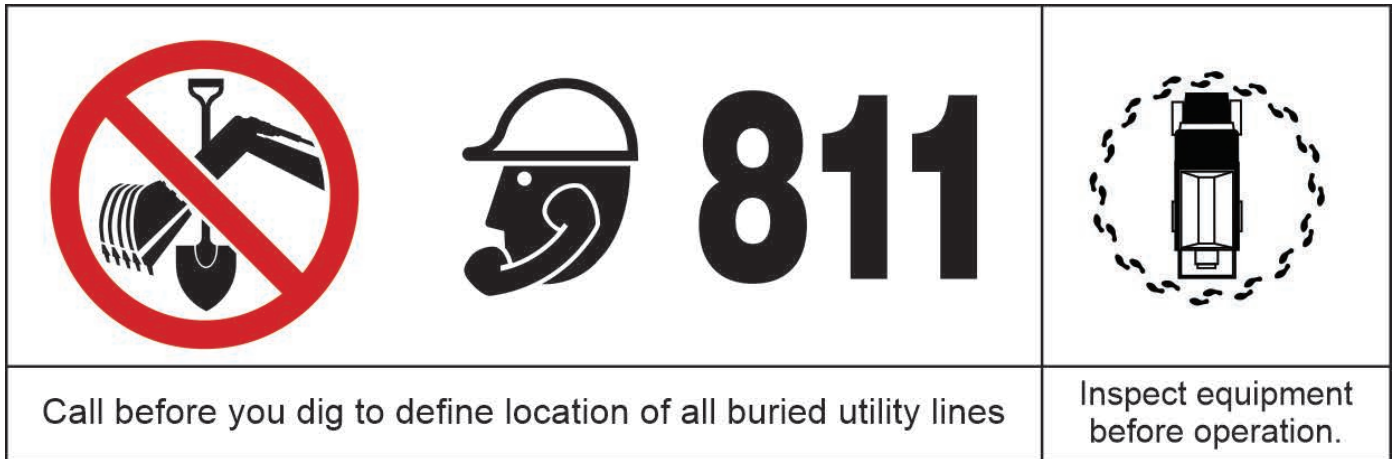

Figure 1-14

 WARNING
<p>Job site hazards could cause death or serious injury. Use correct equipment and work methods. Use and maintain proper safety equipment.</p>

To Help Avoid Injury

If job site classification is in question or if the possibility of unmarked electric utilities exists, classify the job site as electric.

Arrange for Traffic Control

- If working near a road or other traffic area, contact local authorities about safety procedures and regulations.
- Always activate beacons and flashers before job setup.
- Always use safety cones.
- If working on a roadway, follow required temporary traffic control measures.
- Use job site controls, such as cones and barricade tape, to prevent bystanders from entering potentially hazardous areas and to keep them away from machinery.

Prepare for Working Near Existing Utilities

- Boots must have high tops and meet the electric hazard protection requirements of ASTM F2413 OR ASTM F117, when tested at 14,000 volts. Tuck legs of pants completely inside boots.
- Gloves must have 17,000 AC maximum use voltage, according to ASTM specification D120. If working around higher voltage, use gloves and boots with appropriately higher ratings.

Plan for Emergency Services

- Make sure you have the telephone numbers for local emergency and medical facilities on hand, and access to a telephone.

Job Site Safety and Hazard Warnings — continued

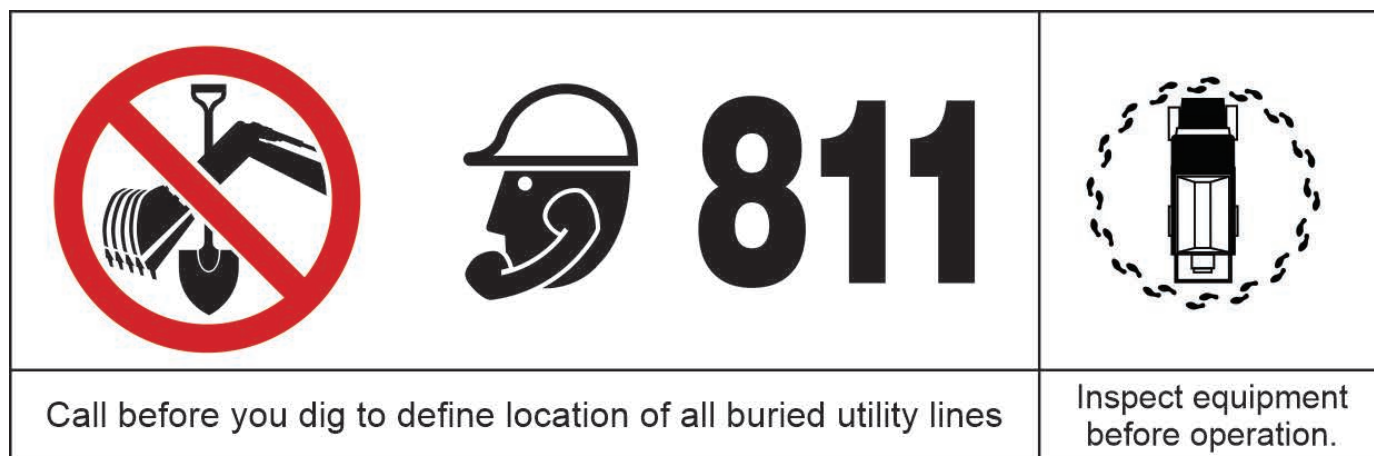

Figure 1-15

Inspect the Job Site

- Follow U.S. Department of Labor regulations on excavating and trenching (Part 1926, Subpart P) and other similar regulations.
- Contact your local One-Call (811 in USA) or the One-Call referral number (888-258-0808 in USA and Canada) to have underground utilities located before digging. Also contact any utilities that do not participate in the One-Call service.
- Inspect job site and perimeter for evidence of underground hazards, such as the following:
 - “Buried utility” notices
 - Utility facilities without overhead lines
 - Gas or water meters
 - Junction boxes
 - Drop boxes
 - Light poles
 - Manhole covers
 - Sunken ground
 - Mark location of all buried utilities and obstructions
- Walk and inspect job site for unsafe conditions and identify any potential hazards for operators and bystanders. Do not operate equipment if unsafe conditions cannot be controlled.

Visibility Conditions When Operating

- **Operate in daylight** or with lights that provide adequate visibility to perform job safely.
- **Make sure** passersby, steep slopes, ditches, drop-offs, overhead obstructions, and power lines are visible and identifiable.

Prepare the Job Site

- Open manholes and other access openings create risk of trips and falls. Be aware of such locations and do not step in or over them. Ensure manhole covers and other covers are in place prior to leaving the job site.
- Be aware of traffic and pedestrians on the job site. Use extreme caution while moving around the vehicle to avoid contact with other moving vehicles. Before stowing the boom or moving the vehicle, make sure pedestrians are clear of the area.
- Clear the area to be excavated. Remove rocks or branches too large for vacuum hose.
- Select a solid area to stand on while excavating.

Fire Extinguisher

If required, mount a fire extinguisher near the power unit but away from possible points of ignition. The fire extinguisher should always be classified for both oil and electric fires. It should meet legal and regulatory requirements.

Vacuum Equipment Operation Safety and Hazard Warnings

1



			
<p>Read and Understand Operator's Manual.</p>	<p>Ensure truck parking brakes are set.</p>	<p>Inspect equipment before operation. Ensure all components are operating properly.</p>	<p>Emergency Stop Button.</p>

Figure 1-16

It is the operator's responsibility to be knowledgeable of all potential operating hazards and to take every reasonable precaution to ensure that oneself, others, animals, and property are not injured or damaged by the operation of this equipment. Do not operate the equipment if passersby or untrained persons are within the active job site.

Never operate this equipment if a shield or guard is missing or in poor operational condition.

NOTE

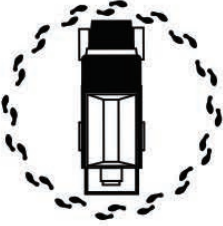
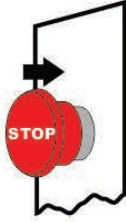
Read and understand all operating instructions and the entire safety section of this manual and the truck manual before attempting to operate any equipment.

If you do not understand any of the instructions, contact your nearest authorized dealer for a full explanation. Pay close attention to all safety signs and safety messages contained in this manual and those affixed to the unit.

 **WARNING**

READ, UNDERSTAND, and FOLLOW the following Safety Messages. Serious injury or death may occur unless care is taken to follow the warnings and instructions stated in the Safety Messages. Always use common sense to avoid hazards.

 **WARNING**

Always set the truck parking brakes and chock the wheels. Unexpected truck movement can cause serious injuries.

Before operating the equipment, conduct a walk-around inspection of the equipment for proper operation. Repair any improperly functioning, broken, or damaged equipment before operating.

Inspect the job site for unsafe conditions and identify any potential hazards for operators and bystanders. Do not operate equipment if unsafe conditions cannot be controlled.

Emergency Stop Button Function

This equipment is equipped with multiple emergency stop buttons that can be activated at any time during operation to disconnect the power and shut down the vacuum, boom, and body operation. Emergency stop buttons are located on the drivers side, passenger side, and each remote pendant.

Pressing the emergency stop button while the machine is in operation has the following results:

- Brings truck RPM to idle
- Opens the vacuum relief valve

Vacuum Equipment Operation Safety and Hazard Warnings — continued



			
<p>Read and Understand Operator's Manual.</p>	<p>Ensure truck parking brakes are set.</p>	<p>Inspect equipment before operation. Ensure all components are operating properly.</p>	<p>Emergency Stop Button.</p>

Figure 1-17

To Restore Power

1. The operator must reset the E-Stop button.
 - Twist the emergency stop button, and it will pop out
2. Upon resetting the emergency stop switch, the truck does not automatically go back to the state it was in when the button was pushed.
3. The switch panel must have power restored to continue operation.
 - The engine RPM must be increased

Vacuum Operation Safety

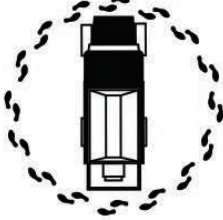
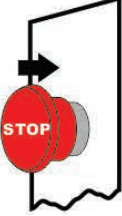
WARNING

When operating the vacuum equipment with extended vacuum hoses or tubes lying horizontal on the ground, you must install a vacuum relief T-type valve in the hose line.

NEVER operate the vacuum system without the vacuum relief valve being installed. Failure to install and operate the vacuum relief valve properly may result in serious injury and/or death.

The in-line vacuum relief valve must be in line within 50 feet from the end of the hose or pipe for proper operation.

WARNING

Make sure no one is near the end of the vacuum hose and that the vacuum relief door is open before engaging the vacuum pump. Failure to do so could cause personal injury.

- Keep vacuum tools and hoses away from face and body. An injury caused by vacuum can be serious. The vacuum must be stopped or the vacuum pressure relieved as quickly as possible at any sign of danger. Seek medical attention immediately.
- Do not attach hose, pipe, or accessories with the vacuum on. The vacuum can trap fingers, hands, and feet with enough force to crush or cut.
- Do not use a bare open hose end for vacuuming. A variety of hose and attachments are available to keep the operator clear of the hose opening.

Vacuum Equipment Operation Safety and Hazard Warnings — continued



CAUTION

Failure to engage parking brakes and/or position wheel chocks could result in unexpected chassis movement, which could cause bodily injury or property damage.



DANGER

Never operate engines where there are or can be combustible vapors. Vapors pulled into an engine air intake can cause engine acceleration and over speeding. This can result in death, injury, and property damage.

Pre-Start Checklist

- Ensure operator and co-workers have read and understood the safety instructions in the Operator's Manual.
- Ensure that all required maintenance has been performed.
- Park truck on level ground and set parking brakes.
- Ensure cleanout doors and tailgate are closed and latched shut.
- Attach suction hose and tubing as required, including relief valve.
- The unit must be thoroughly cleaned between jobs to prevent cross-contamination or chemical reactions.
- Cleaning chemicals must be compatible with the residual debris material to prevent hazardous reactions.
- Cleaning chemicals must be compatible with equipment seals to prevent equipment damage.

- The use of this equipment in the removal or handling of any regulated substance or material must be performed in strict accordance with all applicable federal, state, and local laws and regulations. Approved safety and personal protection equipment and clothing must be used and worn at all times.
- Never use a vacuum machine to vacuum dusty materials until the material safety data sheets (MSDS) have been consulted to determine if the dust is combustible. Only air mover units that are part of a verified assured grounding system and that have bags, doors, and any other non-welded debris body components grounded to the debris body can be used if the materials contain combustible dusts.

Vacuum Operation

NOTE

See "Vacuum Relief Valve Safety" on pages 1-19–1-22.

- Never use the vacuum in any type of rescue operation.
- Operating the unit inside a building or confined areas can create additional risks to the unit, operators, and building occupants. Engine exhaust gas can reach deadly levels. Heat buildup from the engine and blower discharge can overheat equipment.
- Never use an air mover machine for vacuuming hydrocarbon or flammable materials unless the flash point of the material is 150°F or higher. Pressurized or pump off loading is not permitted unless the flash point of the material is 150°F or higher, unless nitrogen is present.

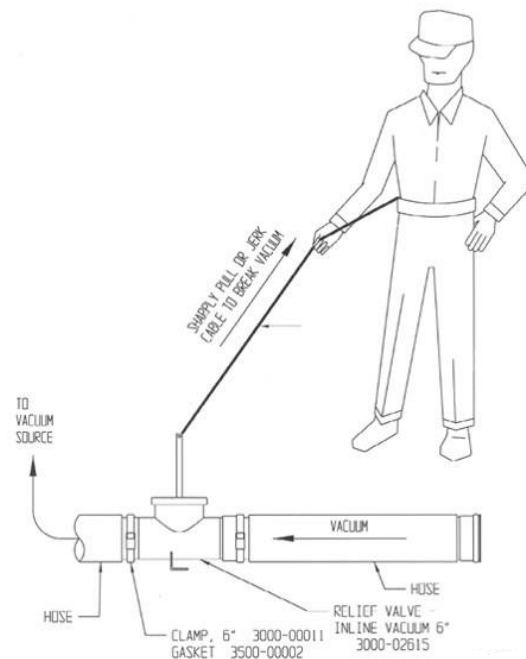

Figure 1-18

Vacuum Relief Valve Safety

Vacuum Relief Valves

The in-line T-type vacuum relief valve is delivered with the unit, and its operation is described in this procedure. The unit will also have a remote-operated vacuum relief valve. It consists of a hinged door that is opened and closed by a pneumatic cylinder. The vacuum relief valve is controlled by the operator at the front control panel or by the wired and wireless pendant remote. Its operation is also described in this section.

- Always use emergency T-type relief valve, except as noted below.
- When safety person is used, make sure he/she is in full view of person(s) at the end of vacuum hose.
- When working close to end of hose, wear tight-fitting clothes. Keep shirts and jackets closed so that shirt tails and jacket tails will not be pulled into end of hose. Remove loose-fitting jewelry such as bracelets and necklaces unless they are under tight-fitting clothing.
- Do not use hand or foot to remove obstructions from end of hose.
- Keep all body extremities and clothing from end of hose.
- The only time the emergency T-type relief valve is not required is when the operator is working vertically off the boom hose. In this case only, the operator should use the remote-operated relief valve. Failure to comply with this requirement could cause bodily injury, for which the manufacturer will not be responsible.

Operating the T-Type Vacuum Relief Valve



WARNING

Test the type T-type vacuum relief valve before using to ensure proper relief operation and to prevent injury or death.

1. With vacuum pump shut down, assemble T-type vacuum relief valve into vacuum inlet tubing or hose. The T-type vacuum relief valve should be kept as close as possible to the person working at the end of the vacuum hose (maximum of thirty feet away). If there is more than one operator, there must be a separate T-type valve for each operator.

2. Place a safety belt around the waist of the person working at the end of the vacuum inlet hose.
3. Attach the end of the pull cord to the loop on the safety belt. It is important to keep the pull cord as short as possible. Depending on how far the person with the safety belt is from the T-type vacuum relief valve, it might be necessary to shorten the pull cord. To shorten the pull cord (always keep pull cord swivel snap attached to loop on safety belt), loop the pull cord through the loop on the safety belt at the length required and knot the loop. During operation, the pull cord should be checked frequently (minimum of every two hours) to see that it can be operated freely and has not been damaged.



WARNING

If the person operating at the end of the vacuum hose is in a confined space or cannot easily reach the pull cord on their safety belt, there must be a safety person(s) wearing a safety belt with a pull cord attached who is in a position to view the person(s) working at the end of the vacuum hose.

4. When needed, the vacuum relief valve can be opened by pulling on the pull cord, which will greatly reduce the amount of vacuum at the end of the inlet hose. To totally eliminate the vacuum at the end of the inlet hose, the vacuum pump should be shut down.
5. With the vacuum pump shut down and the truck's engine off, reset the vacuum relief valve by placing the circular disk on top of the T-section.
6. When the relief valve is not being used, store it properly to prevent damage.

Vacuum Relief Valve Safety — continued

Testing the T-Type Vacuum Relief Valve

NOTE

The following test should be done every time the vacuum relief valve is assembled into the vacuum inlet line or every two hours of during operation, whichever is more frequent.

1. Visually inspect the vacuum relief valve, pull cord, and safety belt. Repair or replace as needed.
2. With the vacuum pump shut down and the truck's engine turned off, assemble the vacuum relief valve in the vacuum inlet line as shown in Figure 1-20. Attach the pull cord to the vacuum relief valve.
3. Insert the male plug into the end of the vacuum relief valve or vacuum inlet hose, whichever is at the inlet point.
4. With the vacuum relief valve closed, start up the vacuum pump and pull full vacuum.
5. At full vacuum, pull the cord to open the vacuum relief valve.
6. After the test, shut down the vacuum pump per operating procedure.
7. Open the vent door to make sure all vacuum is relieved before removing the plug from the end of the vacuum inlet hose.
8. Reset the vacuum relief valve. Remove and store the vacuum relief valve if it is not going to be used.



Figure 1-19



WARNING

If the vacuum relief valve is not working properly, personnel should not be allowed to work at the end of the vacuum inlet hose due to possible injury or death.

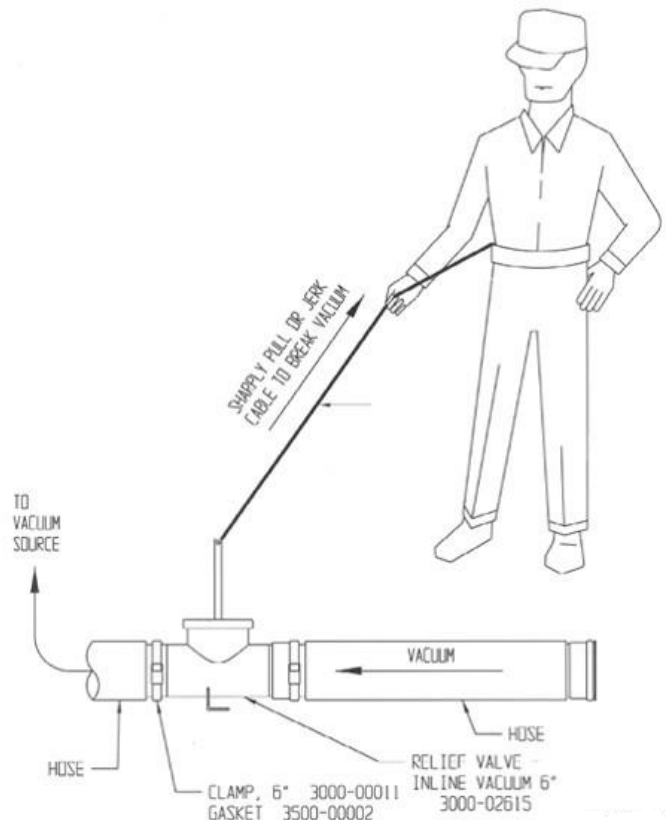

Figure 1-20

Vacuum Relief Valve Safety — continued

Operating the Remote-Operated Vacuum Relief Valve

The remote-operated vacuum relief valve is controlled by the pendant remote control. The operation and testing instructions of this section apply to all relief valve controls.

- A safety person who is in full sight of the operator(s) must be used. The safety person must hold the remote control for the relief valve. Never allow workers at the end of the hose to operate the system without the safety person in position.
- Before cleaning the suction tubes or hoses, lower the engine speed to idle, open the relief valve, turn off the truck's engine, remove the keys, and lock the cab doors.
- When working close to the end of the hose, wear tight-fitting clothes. Keep shirts and jackets closed so that they will not be pulled into the end of hose.
- Remove loose-fitting jewelry such as bracelets and necklaces unless they are under tight-fitting clothing.
- Do not use hands or feet to remove obstructions from the end of the hose.
- Keep all body extremities and clothing away from the end of the hose.

NOTE

See safety instructions for the vacuum relief valve safety.



WARNING

See the section on testing the remote-operated vacuum relief valve before using due to possible personal injury or death.

- For pendant remote control:
 - Insert the pendant cord into the socket located at the front control panel on the passenger side.
 - Route pendant cord to work area. Care should be taken in running pendant cord to work area from truck so that the cord will not be run over or damaged.
- The remote-operated relief valve must only be used with a safety person. The safety person must be holding the remote and must be in a position to observe the person(s) operating the vacuum hose. Never attach the remote to the work hose or to the person actually vacuuming up the product since situations could develop wherein the person using the vacuum hose may not be able to reach the remote.
- If the safety person observes an unsafe or dangerous action of any type, he/she should immediately press the OPEN vent door button on the remote pendant. Only after all potential dangers have been removed should the vent door be closed and normal vacuum operations continue. The safety person should continue to be in a position to observe all vacuum hose operators until those operators have moved a safe distance from the end of all vacuum work hoses.
- After vacuum operation is completed and the vacuum pump is shut down, properly store pendant to prevent damage when truck is being moved.



WARNING

Never move close to the end of any vacuum hose unless the safety person has the remote pendant and is in a position to observe all operators. Failure to comply with this could result in serious personal injury or death.

Vacuum Relief Valve Safety — continued

Testing the Remote-Operated Vacuum Relief Valve

NOTE

The following test should be done every time the pendant is plugged in or every two hours of operation, whichever is more frequent.

1. Visually inspect the pendant cord, electrical plug, and control switch for damage. Repair or replace as needed.
2. If the pendant is not currently plugged in, insert the electrical plug on the end of pendant cord into the socket located at the control panel on the passenger side.
3. With vacuum pump shut down and truck engine off (see operating procedure “ start up and shut down of vacuum pump” in manual) insert male plug into end of inlet vacuum hose.
4. Start up the vacuum pump per operating procedure in manual.
5. With unit at full vacuum, press the VENT OPEN button on the remote and verify that the vacuum relief door has opened. Press the VENT CLOSE button and verify that the vacuum relief door has closed. Observe that the vacuum door has opened by inspecting the Relief Valve Door to ensure it is in the open position.



WARNING

If vacuum relief valve is not working properly, personnel should not be allowed to work at end of vacuum hose due to possible personal injury or death. Repair or replace valve before operating vacuum pump.

6. After testing, shut down the vacuum pump per operating procedure.



CAUTION

Never work beyond the distance from the truck that the wireless remote control was previously tested at. Failure to comply could result in equipment not properly operating.

High-Pressure Water Safety and Hazard Warnings

			
Pressurized fluid and erosion of flesh Hazard	Injection Hazard	Wear protective gloves	Wear face protection - Face Shield

Figure 1-21

- Release pressure before attempting to open any door, hatch, hose, or tube.
- Do not bend or strike high-pressure lines.
- Report any loose or damaged tubes or hoses to mechanics so repairs can be made prior to continued use.

 WARNING
<p>In the event of any water jet injury:</p> <ul style="list-style-type: none"> • Seek medical attention immediately! • Inform the physician of the cause of the injury. • Tell the physician what type of water jet project was being performed at the time of the accident and the source of the water.

Operators using or working around high-pressure water systems need to take additional precautions, including specialized personal protection equipment. This and additional information on high-pressure water safety is provided by and available as a wallet card from:

Water Jet Technology Association
 906 Olive Street, Suite 1200
 St Louis, MO 63101-1419
 (314) 241-1445
 fax (314) 241-1449
 e-mail: wjta@wjta.org
 website: www.wjta.org

IMPORTANT MEDICAL INFORMATION!
<p>READ THIS PLASTIC CARD AND KEEP IT IN YOUR WALLET. IN THE EVENT OF A WATERJET INJURY, SHOW THE CARD TO YOUR DOCTOR.</p>
<p>Distributed by the: WaterJet Technology Association, 906 Olive Street, Suite 1200 St Louis, MO 63101-1419, phone: (314) 241-1445, fax: (314) 241-1449 e-mail: wjta@wjta.org website: www.wjta.org</p>

Figure 1-22

- Use the handgun wash-down system for final equipment and job site cleanups or for cleaning debris buildups on the inside of body.

 DANGER
<p>The water handgun operates at high pressure. Never point the water handgun at yourself or others. Make sure you are holding handgun securely with both hands, in a secure stance. Water gun has a kickback when turned on.</p>

- Always bleed the pressure from the handgun before disconnecting it from the high-pressure handgun connection.

Dust Hazard and Explosion Prevention Safety

1



Figure 1-23

In a confined area, certain concentrations of dust in an otherwise normal atmosphere can explode when spark occurs. This phenomenon is known as a dust explosion. It has been known to occur in grain elevators, underground mines, flour mills, crushers, etc. The dust itself need not be an explosive or flammable substance.

The safe operation of transferring potentially explosive dust should be addressed by the following:

- Static charge dissipation
- Spark prevention

See “Static Charge Dissipation” on page 1-28 and “Spark and Fire Prevention Safety” on page 1-28 for specific information on addressing these two concerns.

Hydrocarbon Waste Recovery







				
Chemical Burning Skin Hazard	Fire Hazard	Explosion Hazard	No Smoking	Never have an open flame

Figure 1-24

 **DANGER**

Do not vacuum flammable or combustible materials unless you have read, understand, and follow these instructions and are fully trained. Failure to do so could result in death or injury.

 **DANGER**

Do not vacuum flammable or explosive materials with a rotary lobe blower.

Most Supersuckers are equipped with a rotary lobe vacuum pump to vacuum materials into the debris tank. The rotary lobe vacuum pump includes metallic lobes within a metallic housing which may produce a spark if the pump becomes damaged. Additionally, rotary lobe vacuum pumps have the potential to produce significant amounts of heat which could be a source of ignition if not carefully maintained and managed.

Never use a rotary lobe blower to vacuum materials with flash points below 150°F. However, hydrocarbon materials with flash points greater than 150°F may be picked up with a rotary lobe blower if the following four concerns are addressed:

- Controlling the lower explosive level (LEL)
- High temperature prevention
- Static charge dissipation
- Spark prevention

 **DANGER**

It is not recommended that materials with a flash point below 150°F be picked up under any operating conditions with a rotary lobe blower.

A rotary lobe blower may be used to pick up materials with flash points greater than 300°F without addressing the four concerns.

Refer to API Standard 2219 for more information on safe operation of vacuum trucks in petroleum service.

Some Supersuckers may be equipped with a LIQUID RING vacuum pump which uses water (or glycol mixture) to create the vacuum seal and to cool the vacuum pump. While cooler than a rotary lobe vacuum pump, the operating temperature of a LIQUID RING vacuum pump must still be monitored and maintained when picking up flammable or combustible materials. Use extreme caution before vacuuming materials that may be combustible or flammable. Hydrocarbon materials may be picked up with a LIQUID RING blower if the following concerns (as described in the following pages) are addressed:

- Controlling the lower explosive level (LEL)
- High temperature prevention
- Static charge dissipation
- Spark prevention

AND

Follow API-2219 Safe Operation of Vacuum Trucks in Petroleum Service, including:

- Hazardous Material Awareness and Identification
- Personal Protective Equipment
- Atmospheric testing
- Conductive Hose
- Bonding and Grounding
- Vacuum Exhaust Venting

Controlling Lower Explosive Level (LEL)

Super Products recommends that a monitor for hazardous hydrocarbon concentrations be installed in the exhaust stream of the vacuum pump to continuously monitor for lower explosive level (LEL). The monitor must be properly calibrated based on the product being picked up.

For details on how the monitor operates, it is suggested you contact a reputable monitor manufacturer such as Industrial Scientific Corporation in Oakdale, PA at 1-800-338-3287.

If the LEL reading approaches 50%, it is recommended that the operator at the end of the work hose lift the hose out of the material being conveyed and allow only air to enter the vacuum hose. As an alternative, a bypass switch could be installed to open the two valves discussed in “High Temperature Prevention” below.

1

High-Temperature Prevention

 DANGER
Failure to comply with the recommendations for high-temperature prevention could result in equipment failure, personal injury, or death.

We suggest that in order to pick up materials with flash points below 300°F, primary and backup system sensors and air flow modifications to limit operating temperatures should be made to a standard vacuum system as manufactured by Super Products. They include the addition of two temperature gauges with adjustable switches, and two temperature sensors, which should be installed in the exhaust airstream of the vacuum pump. In addition, two air-operated valves should be installed on the body. The temperature sensors and gauges should be similar to a Murphy temperature “switch gauge” whereby a contact closes, permitting use of an electrical signal at temperatures above an adjustable preset temperature. The valves should have a minimum four inch diameter.

In operation, the operator should set the trip point of the temperature switches at or below the flash point of the material being picked up. If the exhaust temperature reaches the set point of the temperature switch, the valves would open. This would stop the conveyance of material through the vacuum hose, permit cool air to be sucked into the body and vacuum system for cooling the vacuum pump, and quickly vent from the body so as to not cause an explosion. Prior to each load being vacuumed, the operator should test each system to ensure the valves are working.

The operator should set the trip point of both Murphy gauges to the lowest possible setting, block off the intake hose, and operate the vacuum pump at a minimum of 1000 RPM until the temperature rises to the trip point. The operator should ensure that once the temperature has reached the trip point, the respective valve opens.

 DANGER
Do not use the unit unless both temperature limitation systems are working properly.

Static Charge Dissipation



DANGER

Failure to comply with the recommendations for static charge prevention could result in equipment failure, personal injury, or death.

When picking up potential explosive materials (either hydrocarbons with flash points below 300°F, or explosive dust), it is necessary to safely dissipate static charges by completely grounding the vacuum truck, intake hose, and container from which the material is being removed. Only a static dissipating vacuum hose supplied by Super Products should be used. There should be a grounding strap run from the truck frame to a grounding stake.

All grounding cables should be a minimum of 1/0 in size. Grounding lugs should be welded onto the male and female couplings of all hose sections so that grounding straps (min. #10 gauge wire) can be run from the male coupling to the female coupling at all connection points. A grounding reel should be installed on the vacuum loader with the ground cable run to the container from which the material is being removed.

When material is being transferred by a pneumatic conveying system, static electricity is generated. If this electricity is not dissipated through an electrical ground, arcing can occur. The resulting spark can cause a dust explosion or a hydrocarbon explosion either within the unit or within a building that the conveying line enters.

The following safeguards are recommended to dissipate static charge caused by operation of the unit:

- Truck tires can insulate the unit; therefore, an electrical wire should be connected between the body and a known electrical ground such as a water pipe, plant ground loop system, or metal stake driven into the ground sufficiently deep to ensure an electrical ground. Bolt wire to truck frame — do not weld.
- The electrical resistance from the truck to the electrical ground must be at 10 ohms or less for the duration of the material transfer process. Some companies, such as Newson Gale, provide a ground verification system to enable operators to establish safe grounding of their vehicle.

- Supertube and hose couplers have rubber sealing gaskets. The presence of dirt and corrosion can prevent electrical conduction from tube to tube through the tube clamps. It is recommended to weld a bolt or a threaded stud to each end of each tube or hose coupler, and connect a wire of sufficient length from tube to tube after installation of the clamp. Wing nuts could assist in making these connections quickly.
- Standard Super Products material handling hoses are specially designed to conduct static electricity. Do not substitute hoses of unknown construction, particularly plastic hoses, which may not be static conducting.
- Never operate the unit inside a building that has a dust-laden atmosphere, such as inside of a grain elevator. The unit's electrical system and electrical components will arc in normal operation. Sparks and flame could also be emitted from the engine exhaust. Any of these conditions could cause a dust explosion within the building.
- Before operation, ensure that all ground wire connections are tight and free from corrosion and paint.

1

Spark and Fire Prevention Safety

			
Fire Hazard	Explosion Hazard	No Smoking	Never have an open flame

Figure 1-25



DANGER

Failure to comply with the recommendation for spark prevention could result in equipment failure, personal injury, or death.

When picking up materials with flash points below 300°F, it is necessary to take precautions to prevent generating sparks. Explosion from spark ignition can occur when picking up an explosive product (solid or gaseous). Typically, sparks occur from material striking steel or when metal objects within the material, such as nuts, bolts, or nails, strikes a steel surface. This is especially prevalent where bends in the vacuum piping system occur or inside the collector body when material strikes the floor.

The suggested way of protecting from such an explosion is to use abrasive-resistant rubber-lined elbows where a bend occurs. Line the inside of the material deflector with a rubber abrasion-resistant material and partially fill the debris body with an extinguishing liquid, such as water, so the incoming material does not strike another object, causing a spark. The entire unit should be grounded, as described previously, and only static dissipating hoses should be used. It is essential the truck engine exhaust is directed away from the blower exhaust silencer to avoid an explosion caused by the hot gases or a spark from the engine exhaust.

The vacuum pump exhaust air should only enter the atmosphere at a minimum of 100 feet away from any other potential ignition source.

If the environment in which the truck sits has an explosive gas in the atmosphere, protective measures such as grounding all engine belts, explosive proof alternators, voltage regulators, special truck exhaust mufflers, engine run-away protection devices etc., must be used. Consult the truck manufacturer for details.



DANGER

All of the above situations are extremely dangerous, and all precautionary steps must be taken or else equipment damage, personal injury, or death could occur. If there is any doubt as to the material to be conveyed, a complete analysis must be done prior to vacuuming.

Debris Body Dumping Safety and Hazard Warnings



			
Never go under raised Debris Body	Equipment contacting overhead electrical lines	Hand can be crushed by Debris Body	Truck can tip over when truck wheels are on unstable soil

Figure 1-26

**WARNING**

NEVER leave body raised or partly raised while vehicle is unattended or while performing maintenance or service under body unless body is propped to prevent accidental lowering. The debris body **MUST BE** empty for service work.

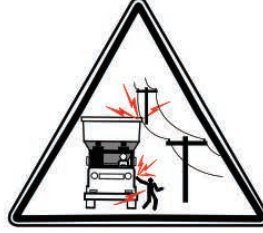
- **Never** prop a raised loaded debris body.
- **Never** attempt to raise body when vehicle is on unlevel ground.

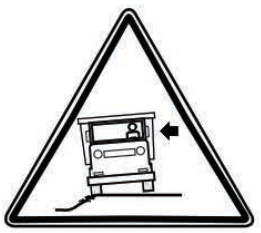
**WARNING**

Never go under a raised loaded debris body. Never go under a raised body without securely propping it. Body must be empty.

- **Immediately** report any damage or malfunction of the unit or components to your employer.
- **Never** ride, or let any other person ride, on any part of the vehicle other than in the cab.
- **Make sure** that all individuals and obstructions are clear of the hoist and body before operating the controls, and be ready to stop operation at any time that a hazardous condition might occur.
- Dispose of all waste in accordance with federal, state, and local laws and regulations.

**WARNING**

Use extreme caution when dumping contents of the debris body. Ensure all personnel are at least 20 feet away from truck. Select a dump site that is on level ground and is clear of overhead obstructions. Serious injury or death to the operator and/or bystanders could occur if precautions are not taken when dumping the contents of the debris body.

- When positioning the truck at the dump station, choose an accessible location on level ground. Raising the debris body on unlevel ground increases the possibility of tipping.
- **Make sure** the area is clear of ground and overhead obstructions.
- **Never** raise the debris body unless you can clearly see all overhead structures. Stay clear of all utility lines.
- **Do not** dump the debris body over a pit area where the ground may cave in or is unstable.
- **Use care** when positioning the debris body to the dump station. Your vision, especially to the side and rear of the debris body, may be reduced by the size of the debris body. Use mirrors to aid vision. If you cannot see the dump site clearly, stop the truck and examine the area. If necessary, request assistance to guide you while backing the truck into position.
- **Never** drive with the debris body in the raised position. Traveling with the debris body in the raised position increases the chances of colliding with overhead obstructions. In addition, the center of gravity of the debris body is higher with a raised debris body, making the unit more prone to tipping over.

Sewer Gas Safety and Hazard Warnings

1

			
Explosion Hazard	Chemical, Dust and Fumes Inhalation Hazard	Wear Respirator when around hazardous fumes	Never have an open flame

Figure 1-27

WARNING

- Sewer lines often contain poisonous or explosive gas such as methane. **NEVER** enter or bend over a sewer without proper ventilation and personal protective equipment. If another person needs help in a sewer, immediately call for emergency assistance. **NEVER** enter the sewer to help unless you have been trained to do so and have proper personal protective equipment.
- **NEVER** smoke in or around sewer lines, drains, or catch basins.
- Failure to follow these instructions may result in death or serious injury.

Confined Space Hazard

Follow all requirements for confined space when servicing. All large water bodies and vessels that can be entered are to be considered permit-required confined space as defined by the Occupational Safety and Health Administration (OSHA). The following information is from OSHA 3138-01R 2004. The full document can be obtained from www.osha.gov.

Many workplaces contain spaces that are considered to be “confined” because their configurations hinder the activities of employees who must enter into, work in, or exit from them. In many instances, employees who work in confined spaces also face increased risk of exposure to serious physical injury from hazards such as entrapment, engulfment, and hazardous atmospheric conditions. Confinement itself may pose entrapment hazards, and working in confined spaces may keep employees closer to hazards such as machinery components than they would be otherwise. For example, confinement, limited access, and restricted airflow can result in hazardous conditions that would not normally arise in an open workplace.

The terms “permit-required confined space” and “permit space” refer to spaces that meet OSHA’s definition of a “confined space” and contain health or safety hazards. For this reason, OSHA requires workers to have a permit to enter these spaces.

By definition, a confined space:

- Is large enough for an employee to enter fully and perform assigned work.
- Is not designed for continuous occupancy by the employee.
- Has a limited or restricted means of entry or exit.

These spaces may include underground vaults, bodies, storage bins, pits and diked areas, vessels, and silos.

Trenching Hazards

NOTE

Reference to OSHA regulations are for informational purposes only and not intended as legal advice.

1



Occupational Safety and Health Administration

Safety Tips





Working safely in trenches





Do **NOT** enter an unprotected trench!

Each employee in a trench shall be protected from a cave-in by an adequate protective system.

Some of the protective systems for trenches are:

- Sloped for stability; or 
- Cut to create stepped benched grades; or 
- Supported by a system made with posts, beams, shores or planking and hydraulic jacks; or  
- Supported by a trench box to protect workers in a trench. 

Additionally, excavated or other materials must be at least 2 feet back from the edge of a trench; and 

A safe means of egress shall be provided within 25 feet of workers in a trench. 

For more complete information:





Occupational Safety and Health Administration
U.S. Department of Labor
www.osha.gov (800) 321-OSHA
TTY (877) 888-5627

OSHA 3243-03R-05

Excavations

OSHA 2226
2002 (Revised)





Occupational Safety and Health Administration
U.S. Department of Labor

De-energize and Lockout Procedures





				
<p>Electrical Wire Hazard</p>	<p>Hand Crushing Hazard</p>	<p>Remove key and read service/maintenance manual/handbook before servicing</p>	<p>Wait until all moving parts have stopped completely</p>	<p>Lock-Out</p>

Figure 1-28

WARNING

Workers can be seriously or fatally injured if machinery they service or maintain unexpectedly energizes, starts up, or releases stored energy.

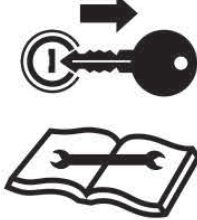
NOTE

Follow all requirements for PPE when servicing equipment.

De-energization and lockout refer to specific practices and procedures to safeguard employees from the unexpected energization or startup of machinery and equipment or from the release of hazardous energy during service or maintenance activities.

De-energization requires the authorized employee to turn off and disconnect the machinery or equipment from its energy source(s) before performing service or maintenance and to either lock out or isolate the equipment/components to prevent the release of hazardous energy (e.g., electricity, compressed air, high pressure fluid, etc.).

Lockout devices hold energy-isolation devices in a safe or “off” position. They provide protection by preventing machines or equipment from becoming energized because they are positive restraints that no one can remove without a key or other unlocking mechanism or through extraordinary means, such as bolt cutters.

To properly de-energize this equipment:

1. Lower the debris body and tailgate to the lowered transport position or onto the mechanical props to support the component.
2. Lower the boom (if equipped) to the storage position or to the lowest or ground position.
3. Place the transmission in the park position.
4. Set the parking brake.
5. Turn off the engine and remove the keys.
6. Switch the battery power off if the truck has a battery disconnect switch, or disconnect the battery ground cables.
7. Lock the truck doors and securely store the truck keys.

Hazards With Equipment Maintenance



WARNING

Avoid serious injury or death from component failure by keeping implement in good operating condition by performing proper service, repairs, and maintenance.

Before Performing Service, Repairs, and Maintenance on the Equipment

- **Stop pto and engine**, engage parking brake, lower equipment, allow all moving parts to stop, and remove key before dismounting from truck.
- **Place** debris body, tailgate, and boom in lowered position or securely block up with support props.
- **Wear safety glasses, protective gloves** and follow **safety procedures** when performing service, repairs and maintenance on the equipment.
- Allow components to cool before servicing or performing maintenance.
- **Avoid contact** with hot hydraulic oil tanks, pumps, motors, valves and hose connection surfaces.
- **Securely** support or **block up** raised framework and lifted components before working underneath equipment.
- **Follow instructions** in maintenance section when replacing hydraulic cylinders to prevent component from falling.
- **Stop** and **shut off truck** engine before doing any work procedures.
- **Use** ladder or raised stands to reach high equipment areas inaccessible from ground.
- **Ensure** good footing by standing on solid flat surfaces when getting on equipment to perform work.
- **Follow** manufacturer's instructions in handling oils, solvents, cleansers, and other chemical agents.
- **Do not** change any factory-set hydraulic calibrations to avoid component or equipment failures.
- **Do not** modify or alter equipment, functions, or components.
- **Ensure the equipment is cleaned appropriately.** Sanitizing may be required if biological hazards are present.

Performing Service, Repairs, Lubrication, and Maintenance

- **Inspect** for loose fasteners, worn or broken parts, leaky or loose fittings, missing or broken cotter keys, washers on pins, and all moving parts for wear.
- **Replace** any worn or broken parts with authorized service parts.
- **Lubricate** unit as specified by lubrication schedule.
- **Never** lubricate, adjust, or remove material while it is running or in motion.
- **Torque** all bolts and nuts as specified.

Safety Shields, Guards, and Safety Devices Inspection

- **Replace** any missing, broken, or worn safety shields, guards, and safety devices.
- **Replace** any damaged or worn safety warning decals. Damaged or worn decals need to be replaced with new ones.

Decal Location

In addition to the decals provided by Super Products there may be decals shown that are part of the cab and chassis or other non Super Products components; these will not be covered.

Some decals shown may appear in a different location than pictured due to differences in optional equipment on each machine and differences in cab and chassis configuration.

If any decal provided by Super Products is missing or becomes illegible, a replacement decal can be requested from Super Products at no charge and should be replaced immediately.

1

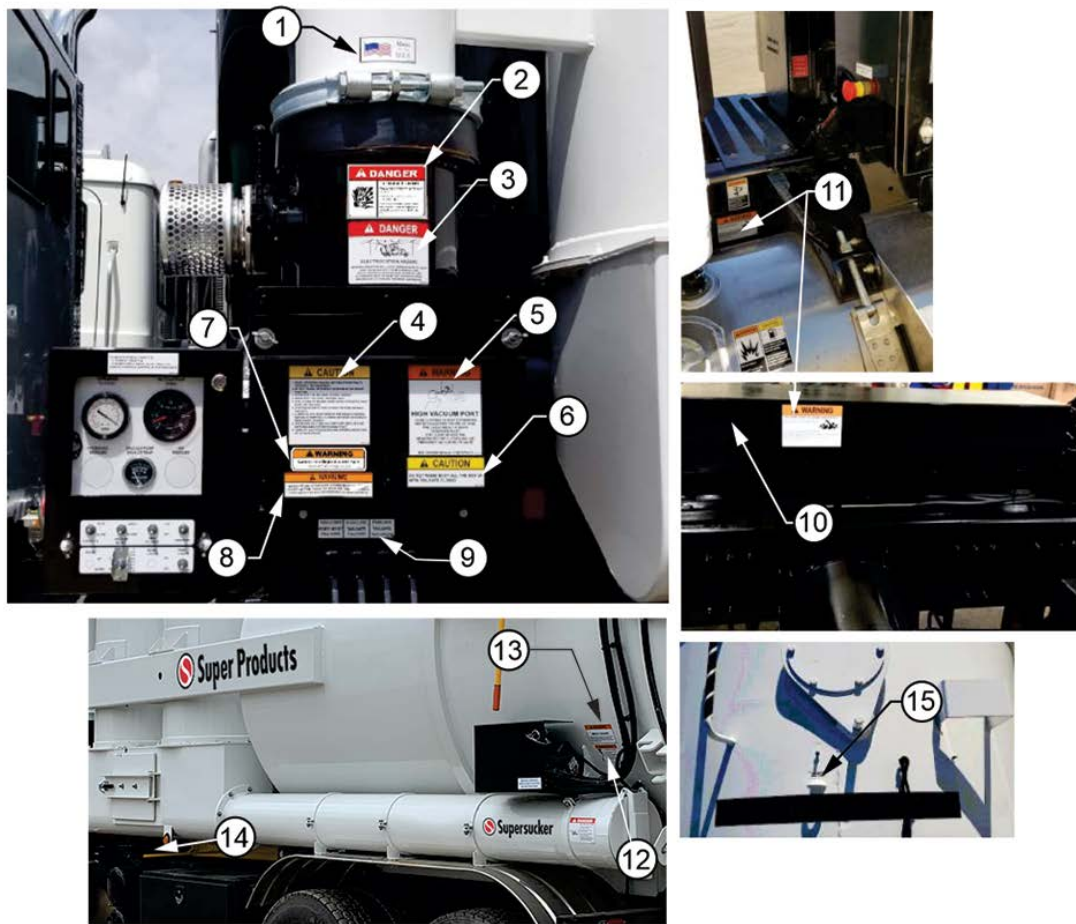
VIEW OF DRIVER SIDE

ITEM	DESCRIPTION	TYPE	PART NO.	SEE FIG.
1	Made in the USA	INSTRUCTION	3050-01222	1-35
2	Hydrocarbon Waste Recovery-Explosion Hazard	DANGER	0026568	1-36
3	Electrocution Hazard	DANGER	3050-01262	1-37
4	Read Operator's Manual	CAUTION	3050-01039	1-38
5	High Vacuum Port	WARNING	3050-00116	1-39
6	Do not raise body	CAUTION	3050-01268	1-40
7	California Prop 65	WARNING	D960	1-41
8	BH & SUP Lid Latching	WARNING	3050-00550	1-42
9	Control Valve	INSTRUCTION	3050-00345	1-43
10	Driveshaft Guard - 48"		0000152	-
11	Entanglement Hazard	DANGER	3050-01179	1-44
12	Pinch Point Hazards	WARNING	3050-01201	1-45
13	Crushing Hazards	WARNING	0003403	1-46
14	Crushing Hazards	WARNING	0007448	1-47
15	OSHA Anchor Point - Not for lifting	WARNING	3050-01222	1-48

Figure 1-29: View of Driver Side

VIEW OF PASSENGER

1

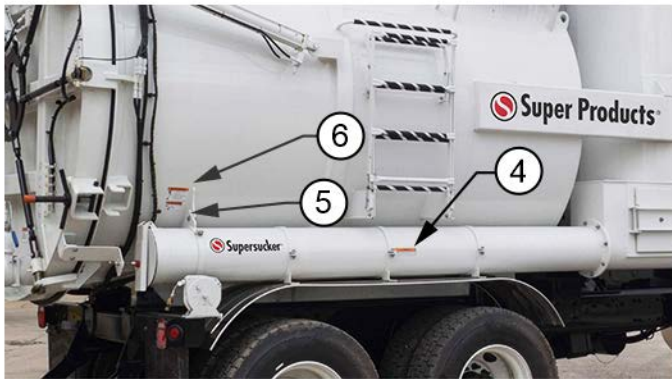
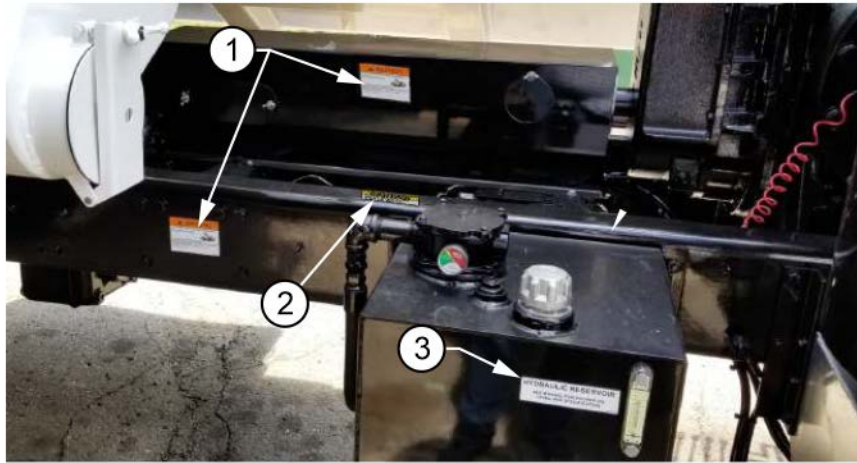

ITEM	DESCRIPTION	TYPE	PART NO.	SEE FIG.
1	Entanglement Hazard	DANGER	3050-01179	1-44
2	Hydraulic Valve Position	CAUTION	3050-01286	1-49
3	Hydraulic Reservoir	INSTRUCTION	3050-00051	1-50
4	BH & SUP Lid Latching	WARNING	3050-00550	1-42
5	Pinch Point Hazards	WARNING	3050-01201	1-45
6	Crushing Hazards	WARNING	0003403	1-46

Figure 1-30: View of Passenger side

VIEW OF REAR KIT

1

ITEM	DESCRIPTION	TYPE	PART NO.	SEE FIG.
1	High Vacuum Port	WARNING	3050-00116	1-39
2	OSHA Anchor Point - Not for lifting	WARNING	3050-01222	1-48
3	Debris Level 1/2 Full	INSTRUCTION	0034920	1-51
4	TG Grease - RH	INSTRUCTION	0035808	1-52
5	Crushing Hazards	WARNING	0003403	1-46
6	TG Grease - LH	INSTRUCTION	0035713	1-53

Figure 1-31: View of Rear

VIEW OF INTERIOR LABEL

1



ITEM	DESCRIPTION	TYPE	PART NO.	SEE FIG.
1	Rear Axle Disengage	INSTRUCTION	3050-00096	1-54
2	Alarm Body Raised	INSTRUCTION	3050-01186	1-55
3	Highest Gear	INSTRUCTION	0002445	1-56
4	Alarm Must Sound	WARNING	0024921	1-57
5	Water Supply	INSTRUCTION	3050-00268	1-58
6	BH & SUP Lid Latching	WARNING	3050-00550	1-42
7	Parts/Service	INSTRUCTION	3050-00193	1-59
8	Engine Parameters	INSTRUCTION	0003392	1-60
9	Transmission	WARNING	3050-01287	1-61

Figure 1-32: View of Interior Label

VEHICLE CERTIFICATION AND INSPECTION



1

ITEM	DESCRIPTION	TYPE	PART NO.	SEE FIG.
1	Final Vehicle Certification	INSTRUCTION	3050-00196	–
2	DOT Annual Inspection Label	INSTRUCTION	0035464	–

Figure 1-33: Vehicle Certification and Inspection

DECAL LOCATION - LIQUID RING VACUUM PUMP



ITEM	DESCRIPTION	TYPE	PART NO	SEE FIG.
1	High Water Level	INSTRUCTION	0040197	
2	Low Water Level	INSTRUCTION	0040198	
3	SS-LR Pump Operation	INSTRUCTION	0042030	1-64
4	Water Fill	INSTRUCTION	0041127	
5	Water Supply Valve	INSTRUCTION	0041128	
6	Drain	INSTRUCTION	3050-00024	
7	Hot Water Hazard	WARNING	0042290	1-62
8	Do Not Run the Pump Without Water	CAUTION	0041123	1-63
9	Explosion Hazard LR	DANGER	0042515	1-65

Figure 1-34 Liquid Ring Vacuum Pump

Decals



Part no. 3050-00433
Figure 1-35



Part no. 0026568
Figure 1-36

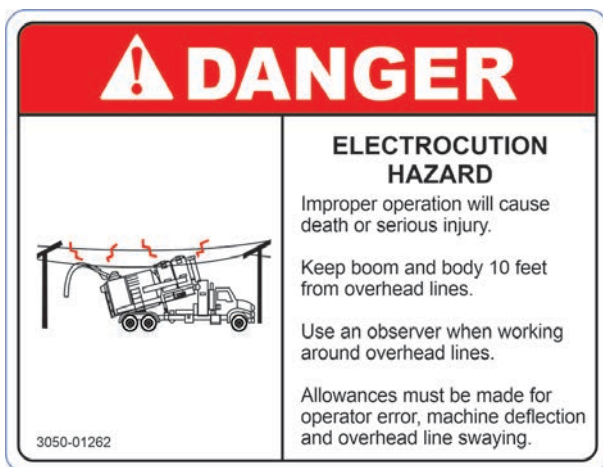

Part no. 3050-01262
Figure 1-37



Part no. 3050-01039
Figure 1-38



Part no. 3050-00116
Figure 1-39

1

1



Part no. 3050-01268
Figure 1-40



Part no. D960
Figure 1-41



Part no. 3050-00550
Figure 1-42

PUSH- LOWER BODY HOIST PULL- RAISE	PUSH- CLOSE TAILGATE PULL- OPEN	PUSH- LOCK TAILGATE PULL- UNLOCK	PUSH- CLOSE BAGHOUSE DOOR PULL- OPEN	PUSH- OFF SEPARATOR PULL- ON	PUSH- OFF WATER WASHDOWN PULL- ON	PUSH- REVERSE PNEUMATIC UNLOADING PULL- FORWARD	PUSH- OFF BODY PRESS PULL- ON	PUSH- OFF TRASH PUMP PULL- ON	HYDRAULIC VIBRATOR RUN	PUSH- OFF BOOM PULL- ON
--	---------------------------------------	--	--	------------------------------------	---	---	-------------------------------------	-------------------------------------	---------------------------	-------------------------------

Part no. 3050-00345
Figure 1-43



Part no. 3050-01179

Figure 1-44

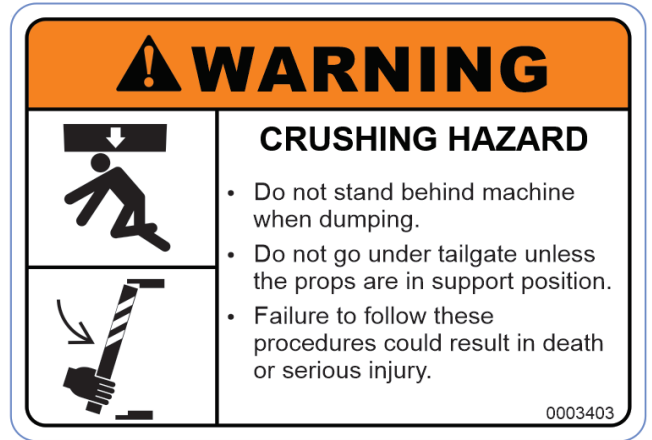

Part no. 0003403

Figure 1-46

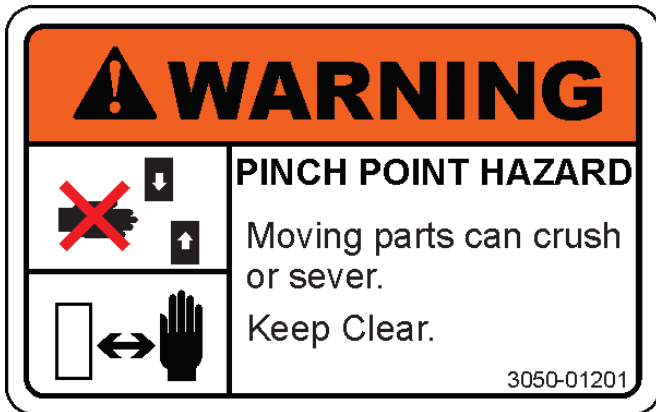

Part no. 3050-01201

Figure 1-45

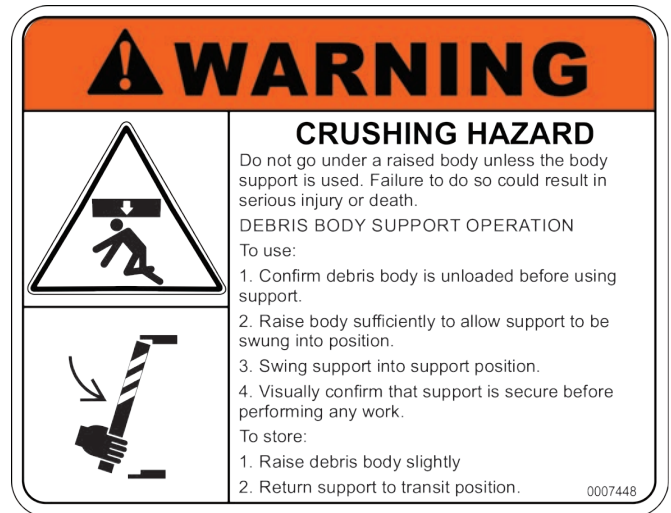

Part no. 0007448

Figure 1-47

1



Part no. 3050-01222
Figure 1-48

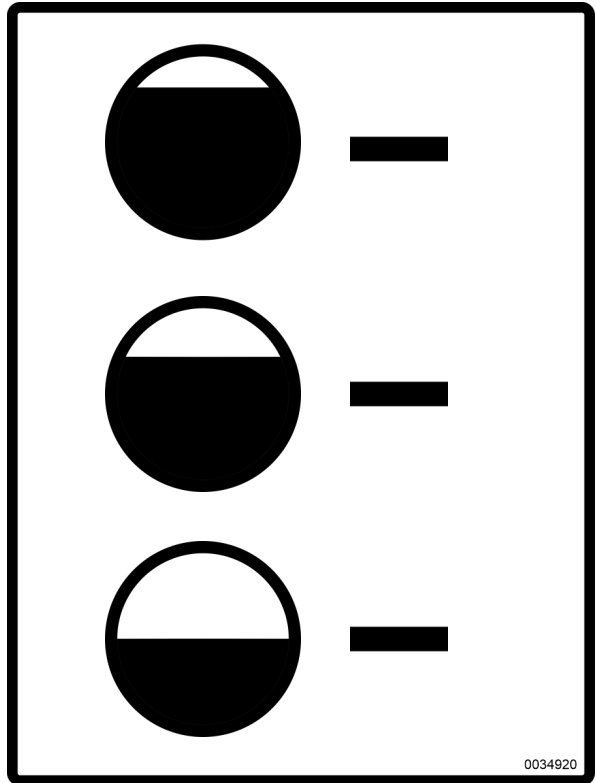

Part no. 0034920
Figure 1-51



Part no. 3050-01286
Figure 1-49



Part no. 3050-00051
Figure 1-50

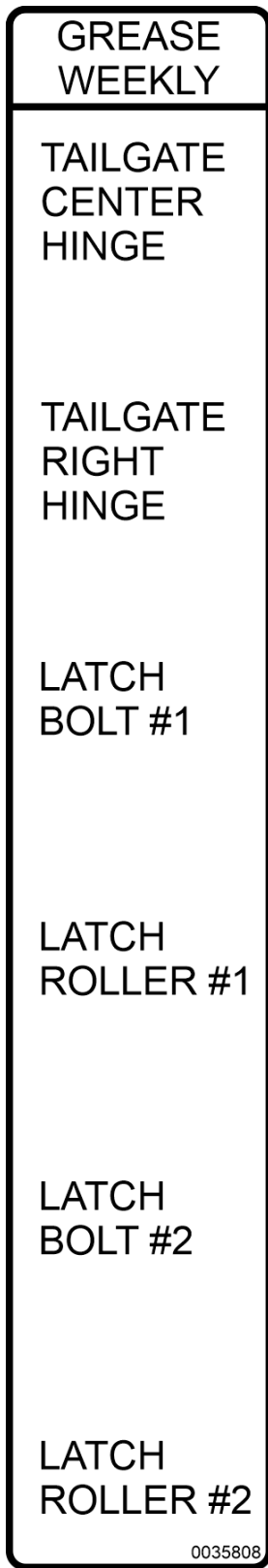

Part no. 0035808
Figure 1-52

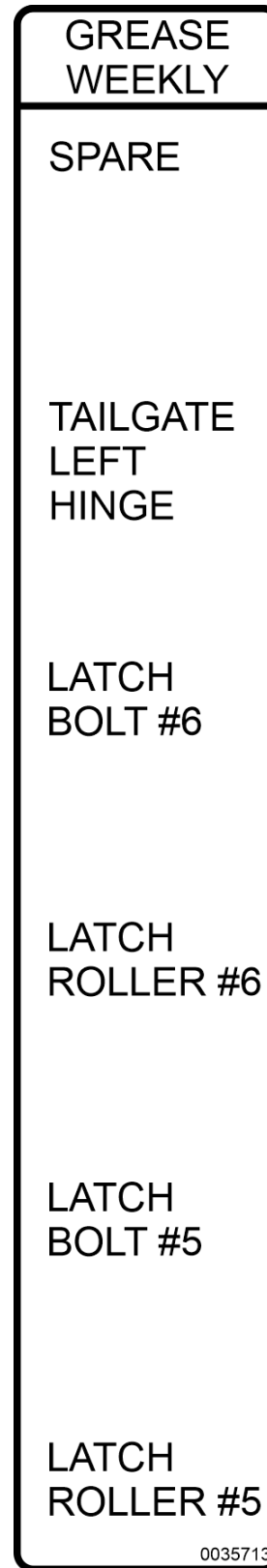

Part no. 0035713
Figure 1-53



Part no. 3050-00096
Figure 1-54

ENGAGED	WHEN REAR AXLE IS DISENGAGED HYDRAULIC PUMP IS ENGAGED	DISENGAGED
REAR AXLE		VACUUM PUMP
DISENGAGED	3050-00268	ENGAGED

Part no. 3050-00268
Figure 1-58



Part no. 3050-01186
Figure 1-55



Part no. 3050-00193
Figure 1-59

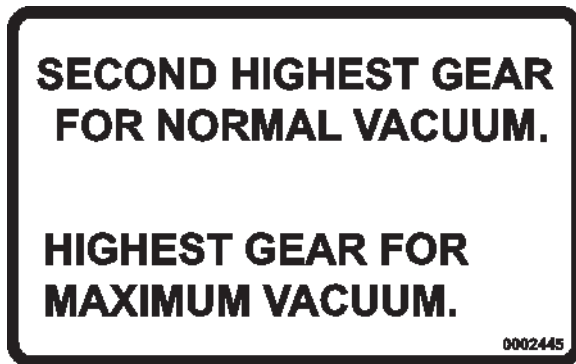

Part no. 0002445
Figure 1-56

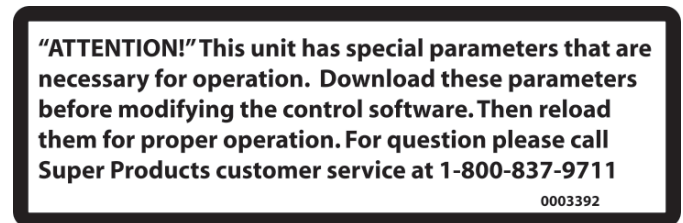

Part no. 0003392
Figure 1-60

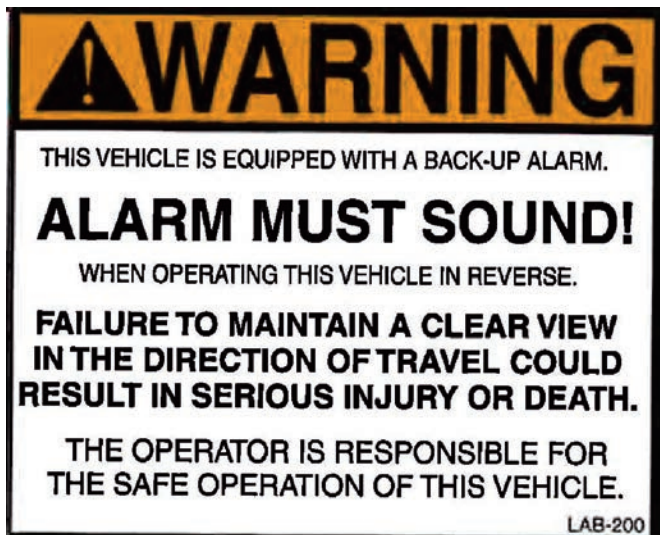

Part no. 0024921
Figure 1-57



Part no. 3050-01287
Figure 1-61

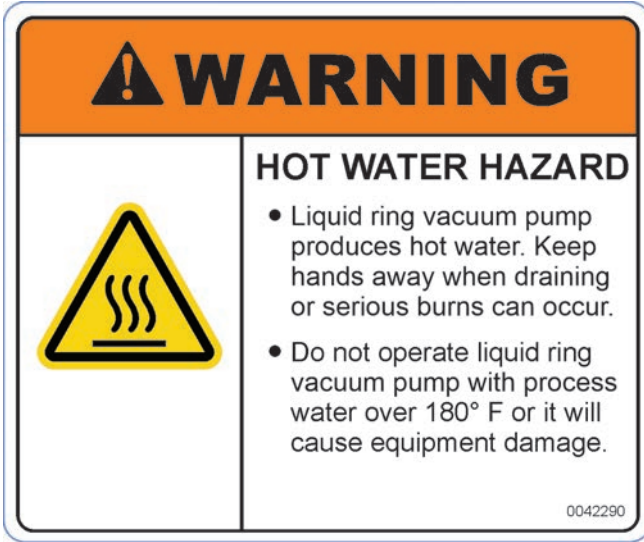

Part no.0042290

Figure 1-62

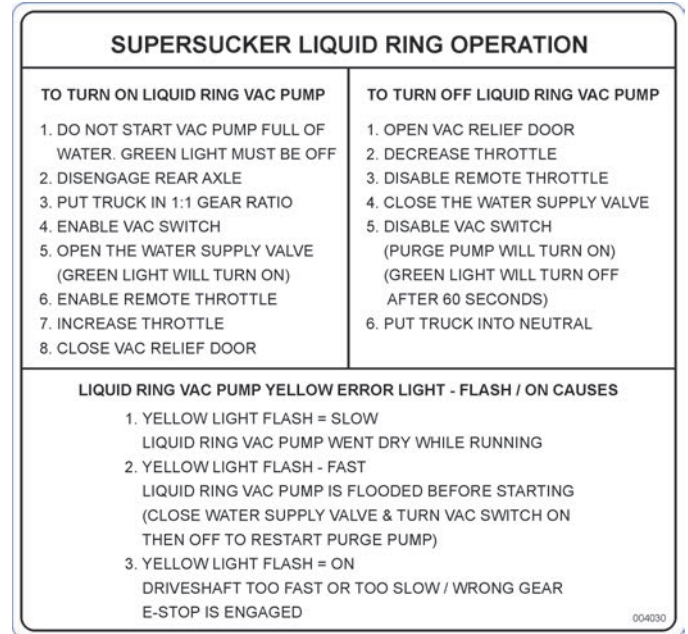

Part no.0042030

Figure 1-64



Part no.0041123

Figure 1-63



Part no.0042515

Figure 1-65

1

Preparation Before Traveling To Worksite

If there are any questions on how to implement the below procedures, contact Super Products prior to starting operation. Super Products will not be responsible for any damage or injuries if all safety procedures are not completely followed.

1

1. Perform required maintenance as specified in Maintenance Schedule for Supersucker.
2. Perform required maintenance on truck chassis. Check oil and water levels in engine, transmission level and fuel level.
3. Check that tailgate is closed and properly locked.
4. Close all water drain valves and install all plugs and strainers previously removed.
5. Check that boom (if equipped) is locked in transport position and properly secured.
6. Check that all tools, accessories, and work tubes/hoses are properly secured.
7. Check that cabinet doors and access panels are closed.
8. Check that all clean-out doors are closed and latched shut.
9. Check that the dust chute and tailgate are closed and latched shut.
10. Drive to work site and position truck so vacuum intake hose can be swung without going into a lane of traffic, if next to a road, or hitting some other obstruction.

Introduction

This manual contains important information regarding safe operation, adjustment, and maintenance for the Super Products' Supersucker® Industrial Vacuum Loader.

DO NOT allow anyone to operate or service this machine until they have read and understood all aspects of this manual.

DO NOT use this machine for any purpose or application other than those listed in this manual. Improper use or neglect of safety precautions will cause serious injury or death. Refer to Section 1, Safety.

NOTE

This operator's manual is to stay with the truck and be used as reference for operator personnel.

Principles of Operation

The Supersucker is designed to pneumatically pick up and convey material in either solid, liquid or slurry form from points near to, or remote from, the machine. The unit uses a fail safe filter system that provides positive protection for the vacuum pump during all operating conditions using the same air flow path.

While operating with either solids or liquids, material is picked up at the end of the suction line and pneumatically conveyed into the body. As conveyed material enters the collector body, the majority falls to the bottom due to gravity and the reduction in air velocity.

Any material still airborne will continue with the air flow to a centrifugal separator. Centrifugal force causes airborne material to be separated from the air stream with the material falling into the storage area beneath the separator and the clean air exiting out the side of the separator.

The air then travels to a baghouse(s) in two lines. The air hits a deflector shield and is forced to the bottom of the baghouse. From there, the air travels through filter bags which catch any particles still in the air.

Clean air continues through a duct and into a final screen. From there it goes through the vacuum pump and is exhausted to the atmosphere through the discharge silencer.

The unit is equipped with a reverse air pulse cleaning system to clean the filter bags. On a timed interval, compressed air from the truck air system is blasted into the center portion of the bags and blows any accumulated dust or moisture off the bags. A timer automatically sequences the blast so all bags get cleaned on a regular basis. The accumulated dust settles at the bottom of the baghouse(s) and is dumped out when the body payload is dumped. The air system uses DOT approved check valves to prevent bleed down of the truck air system pressure.

Equipment Specifications

Maximum vacuum pressure rating of vacuum system = 27" Hg (0.90 bar)

Maximum pressure rating = Not Applicable. This unit is not designed for pressure unloading.

Maximum height in transport configuration = 13'-2" (4,013 mm) w/ Boom

Maximum height in transport configuration = 12'-8" (3,861 mm) w/o Boom

Maximum height with boom raised and extended = 21'-8" (6,604 mm)

Approximate empty weight of stock Supersucker = 40,000 lbs (18,182 kg)

Maximum height in transport configuration = 13'-6" (4,115 mm) w/ High Dump Option

Total gross debris body volume = 18.4 yd³

Usable debris body capacity (when floatball shuts off vacuum) = 15.9 yd³

2

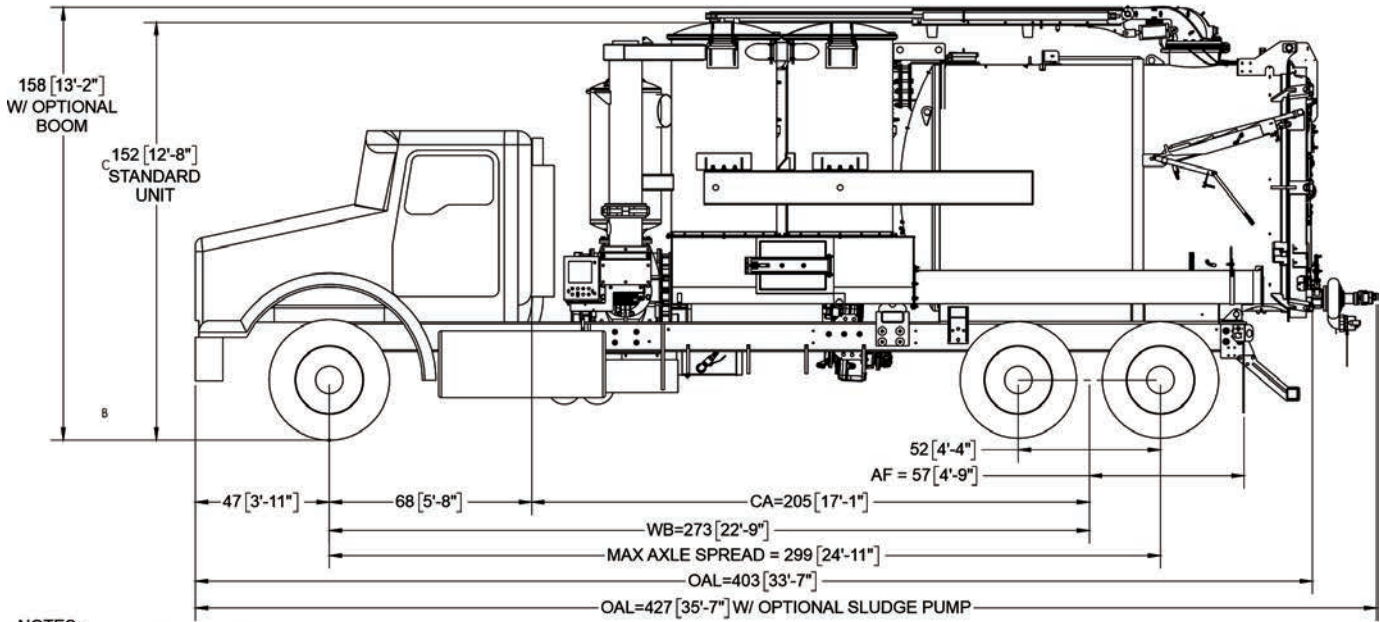

- NOTES:
 1) WIDTH W/ MIRRORS = 110"
 2) MAX BODY WIDTH = 96"
 3) ALL DIMENSIONS AND SPECS. ARE FOR A REFERENCE STOCK TRUCK. ACTUAL VALUES MAY VARY BASED ON CHASSIS MANUFACTURER AND SELECTED OPTIONS.
 4) WARNING! IT IS POSSIBLE TO OVERLOAD THIS VEHICLE. NEVER EXCEED THE GROSS VEHICLE WEIGHT RATING OR GROSS AXLE WEIGHT RATING.

APPROXIMATE AXLE WEIGHT WITH DRIVER AND FULL FUEL (LBS.)			
DESCRIPTION	STEER AXLE	REAR AXLE	GROSS WEIGHT
EMPTY	17,000	23,000	40,000
FULL OF WATER	17,000	49,500	66,500

Figure 2-1

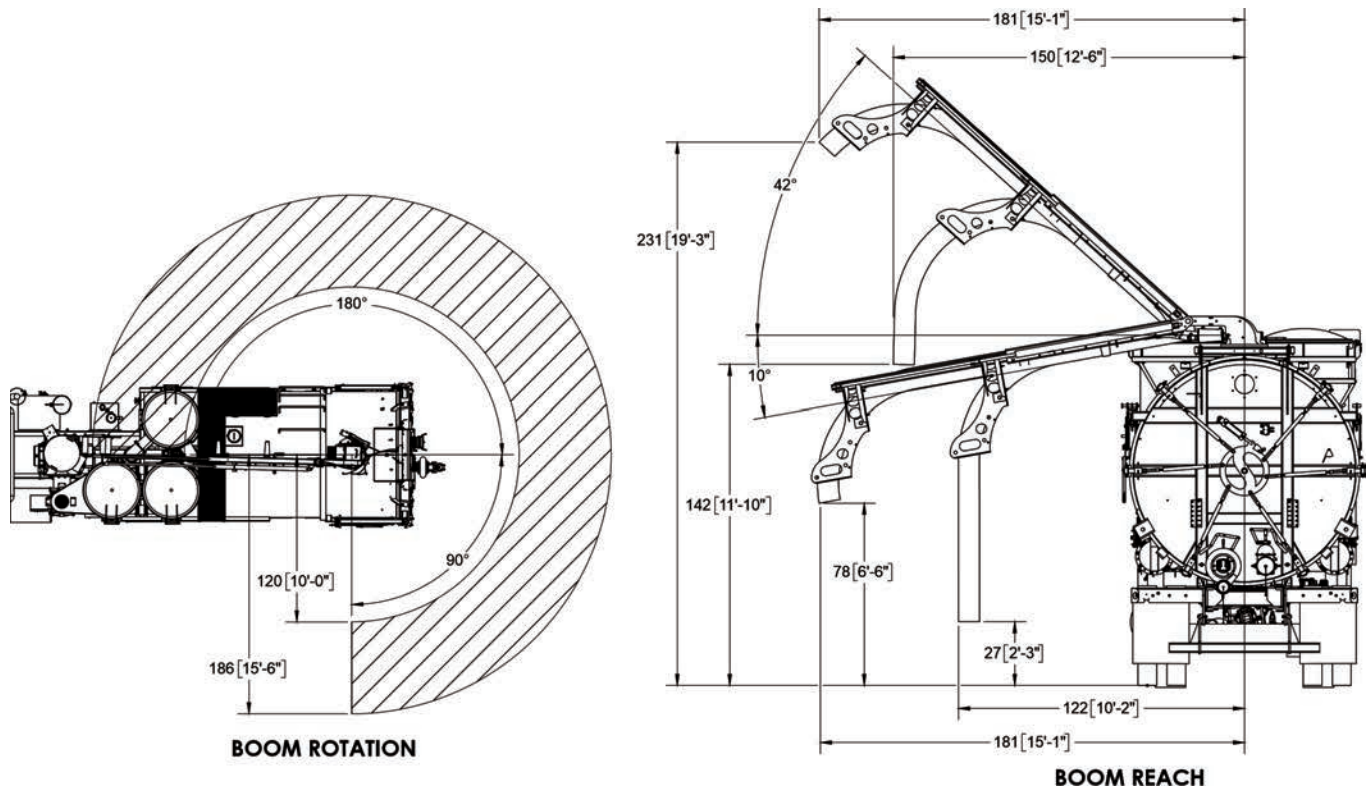

Figure 2-2

Vacuum System

The vacuum system utilizes a positive displacement type of vacuum pump that is mechanically driven from the truck's engine. The vacuum system has the capability of transferring materials using two methods — Pure Vacuum and Air Conveyance.



CAUTION

The vacuum system is designed for liquids, slurries, and damp materials. Dry or dusty materials must be wet down before vacuuming to limit the carryover of debris into the separator and final filter. This can be accomplished with the handgun attachment or by injecting water into the vacuum line with the liquid ring accessory.

Pure Vacuum

As a general rule, pure vacuum would be used for removing sludge from beneath liquid or for rapid liquid loading. In this mode, the vacuum tube is totally submerged in the liquid and only material (no air) transports through the line. With the standard vacuum pump, the maximum distance from the top of the vacuum hose supported by the boom to the liquid surface cannot exceed three hundred sixty-seven (367) inches (30.5) feet at sea level assuming water as the liquid. For materials of a higher density than water, these figures must be reduced. Consult the factory for additional information. In pure vacuum mode, select the transmission gear that is 1:1 ratio (16th gear for 18-speed transmission, 9th gear for 10-speed) or lower. The vacuum pump should be operated at one thousand two hundred (1200) RPM. Operating the unit too fast will decrease performance. Loading rates up to one thousand (1000) GPM through a six (6) inch hose can be realized.

Air Conveyance

The second conveying method is "air conveyance" and requires enough air velocity going past the material to be picked up to capture such, and convey through the vacuum tube to the body. This requires the vacuum pump be operating at a fast enough speed to produce the required airflow to capture the material.

NOTE

It should be noted that the most efficient and highest loading rate occurs when the pump is run as slow as permissible and still pick up the material. Vacuum tube lengths up to one thousand (1000) feet can be used and liquid loading rates up to five hundred (500) GPM through a six (6) inch line can be realized. Select the overdrive transmission gear (18th gear) for air conveyance mode.

IMPORTANT

There are also applications where a vacuum fluidizing nozzle should be used. This combines the benefits of pure vacuum and air conveyance. The fluidizing nozzle has the ability to remove sludge from beneath liquids where the distance exceeds the limitation of pure vacuum.

NOTE

It should be noted that for maximum efficiency, all vacuum line connection points must be air tight. This is accomplished by installing the O-ring gasket over the male end of the tube. Refer to the "Operation Instructions" and "Maintenance Schedule" for further details.

It should also be noted that the vacuum pump should never be operated above a pump exhaust temperature of 320°F. Deviations from this maximum operating temperature must be approved by Super Products.

Airflow

Please refer to below drawing.

1. Material along with air enters body through the boom canon elbow (#1) or through optional rear port (not shown).
2. Air speed is greatly reduced inside body allowing material to separate from air stream. Material settles to the bottom of the body. Air with some fine carryover dust or mist exits the body past the ball float (#2).
3. The ball float (#2) acts as a vacuum shut-off when the body becomes full of liquids.
4. The air exits the body into the separator (#4) located on right side of the unit.
5. The air is spun centrifugally with the majority of the carryover dust and mist settling to the bottom of the separator area.
6. The air continues out the side of the separator (#5) over to the bag houses.
7. The air goes from the outside of the bag (#6) to the inside of the bag. Any remaining material, one (1) micron or larger is captured on the outside of the filter bags.
8. The clean air exits the top of the filter bag (#6) and continues down a duct on the front of the bag house to the make/break connection including the final filter (#7).
9. The material collected on the outside of the filter bags (#6) is blown off the bags using a reverse pulsing system with compressed air from the truck air compressor. See bag pulsing section in manual for details on its operation.
10. The air enters the final filter (#7) area which has a perforated metal screen as a filter.
11. The air goes through the final filter (#7) and into the inlet of the vacuum pump (#8).
12. The air goes horizontally through the vacuum pump where the air normally gets heated up because of the work being done on the air by the vacuum pump. The amount of heat being generated depends on operating vacuum and pump speed.
13. a. The air exits the rotary lobe vacuum pump (#8) and goes through a discharge silencer (#9) before entering the atmosphere at the top of the silencer.
b. The air exits the liquid ring vacuum pump (#11) and exits to the water supply tank (#12) where exhaust air is separated from the exhaust water and released to the atmosphere.
14. Your Super Sucker is a "high" vacuum unit capable of 28" Hg. There is an inlet silencer (#10) bolted directly above the vacuum pump (#8). Cooling air comes from the atmosphere into the top of the silencer and on into the vacuum pump. This air cools the vacuum pump allowing for high vacuum operation.

AIRFLOW, MODULAR SUPERSUCKER

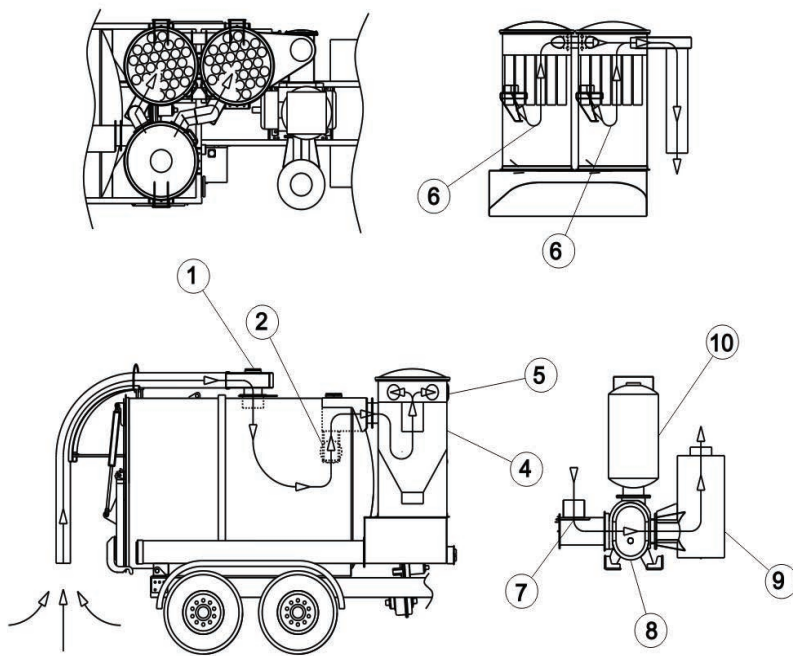

LIQUID RING AIRFLOW

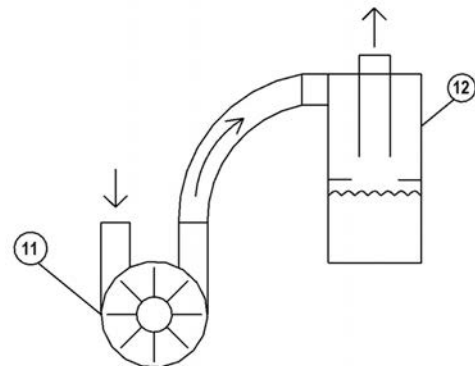

9700-00462-0512

Figure 2-3

Rotary Lobe Vacuum Pump Operation

1. The rotary lobe vacuum pump is driven through a transfer case. For vacuum pump operation, the rear drive axle is disengaged and the vacuum pump is engaged. The transmission should be in neutral (N), parking brakes engaged and wheel chocks properly positioned before beginning the engagement process.



CAUTION

Failure to engage parking brakes and/or position wheel chocks could result in unexpected chassis movement which could cause bodily injury or property damage.

2. Start engine and allow it to idle. Let chassis air build to the maximum 120psi.



CAUTION

Make sure no one is near the end of the vacuum hose and that the vacuum relief door is open before engaging the vacuum pump. Failure to do so could cause personal injury.

3. Transfer Case Engagement. Methods of engagement vary with the chassis transmission and transfer case equipment. Select the section below that matches the configuration of the unit being operated.

a) Manual Transmission with Manual Shift or Air Shift Transfer Case.

- i) Fully depress the clutch pedal.
- ii) Shift transmission into high range.
- iii) Depress clutch and select the proper forward gear which is 1:1 gear ratio. The proper gear should be the highest forward gear which will keep the engine speed above 1000 RPM at the desired vacuum pump speed. For normal vacuuming with the standard 10 speed transmission, use 9th gear.
- iv) If equipped with an air shift transfer case, locate the valve or switch (respectively) labeled "Rear Axle", "RAD", or "Vacuum Pump" between the driver's and passenger seats or on the instrument panel. Move the valve or switch to the "engaged" position.
- v) If equipped with a manual cable shift transfer case, locate the lever between the driver's and passenger seat labeled "Rear Axle". Pull up on the lever until it is fully engaged. It may be necessary to feather the clutch in order to

get full engagement. A light will come on indicating the rear axle is disengaged.

- vi) If equipped with a transmission-mounted PTO, locate the PTO control on the dash for the hydraulic pump. Move the PTO control switch to engaged.
 - vii) Slowly release the clutch. The vacuum pump will be turning at this time.
- b) Automatic Transmission with Manual Shift or Air Shift Transfer Case.

- i) Confirm the transmission gear selector is in neutral (N). Never shift the transfer case with the transmission in drive (D) or reverse (R) or damage will occur.
- ii) If equipped with an air shift transfer case, locate the valve or switch (respectively) labeled "Rear Axle", "RAD", or "Vacuum Pump" between the driver's and passenger seats or on the instrument panel. Move the valve or switch to the "engaged" position.
- iii) If equipped with a manual cable shift transfer case, locate the lever between the driver's and passenger seat labeled "Rear Axle". Pull up on the lever until it is fully engaged. If it does not fully engage, it will be necessary to pull up lightly on the lever while momentarily placing the transmission gear selector in drive (D). Immediately return the transmission gear selector to neutral (N). A light will come on indicating the rear axle is disengaged.
- iv) If equipped with a transmission-mounted PTO, locate the PTO control on the dash for the hydraulic pump. Move the PTO control switch to engaged.
- v) Place the transmission gear selector in drive (D). The vacuum pump will be turning at this time.

4. At the main control panel turn the "Remote Throttle" switch ON.
5. At the main control panel, wireless remote, or pendant increase the vacuum pump speed to the desired level as observed on the tachometer in the main control panel. Run the vacuum pump at the slowest speed possible to reduce fuel consumption and wear, limit carryover and have a quieter machine. To maintain proper lubrication, do not run the vacuum pump slower than 900 RPM. Never exceed 2000 RPM with the vacuum pump engaged. Do not run the engine slower than 1000 RPM. Do not run the engine slower than 1200 RPM when Bag Pulsing is ON.

- 2
6. When it is time to vacuum material, close the vacuum relief door by operating the switch on the control panel, wireless remote or pendant. The vacuum relief door switch on the main control panel must be in the "closed" position for the vacuum relief door to close.
 7. When it is time to vacuum material, close the vacuum relief door by operating the switch on the wireless remote, or pendant. The vacuum relief door switch on the main control panel must be in the "closed" position for the vacuum relief door to close.
 8. When done vacuuming, open the vacuum relief door. Reduce the engine speed to idle and turn "Remote Throttle" OFF.
 9. Transfer Case Disengagement.
 - a) Manual Transmission with Manual Shift or Air Shift Transfer Case.
 - i) Fully depress the clutch pedal and wait five to ten seconds for the driveline to stop turning.
 - ii) If equipped with an air shift transfer case, locate the valve or switch (respectively) labeled "Rear Axle", "RAD", or "Vacuum Pump" between the driver's and passenger seats or on the instrument panel. Move the valve or switch to the "disengaged" position.
 - iii) If equipped with a manual cable shift transfer case, locate the lever between the driver's and passenger seat labeled "Rear Axle". Push down on the lever until it is fully engaged. It may be necessary to feather the clutch in order to get full engagement. A light will go out indicating the rear axle is engaged.
 - iv) If equipped with a transmission-mounted PTO, locate the PTO control on the dash for the hydraulic pump. Move the PTO control switch to disengaged.
 - v) Shift transmission into neutral and slowly release the clutch. The vacuum pump should not be turning at this time.
 - b) Automatic Transmission with Manual Shift or Air Shift Transfer Case.
 - i) Place the transmission gear selector in neutral (N). Never shift the transfer case with the transmission in drive (D) or reverse (R) or damage will occur.
 - ii) If equipped with an air shift transfer case, locate the valve or switch (respectively) labeled "Rear Axle", "RAD", or "Vacuum Pump" between the driver's and passenger seats or on the instrument panel. Move the valve or switch to the "disengaged" position.
 - iii) If equipped with a manual cable shift transfer case, locate the lever between the driver's and passenger seat labeled "Rear Axle".

Push down on the lever until it is fully engaged. If it does not fully engage, it will be necessary to push down lightly on the lever while momentarily placing the transmission gear selector in drive (D). Immediately return the transmission gear selector to neutral (N). A light will go out indicating the rear axle is engaged. The vacuum pump should not be turning at this time.

- iv) If equipped with a transmission-mounted PTO, locate the PTO control on the dash for the hydraulic pump. Move the PTO control switch to engaged.

Liquid Ring Vacuum Pump Operation

1. The liquid ring vacuum pump is driven through a transfer case. For vacuum pump operation, the rear drive axle is disengaged and the vacuum pump is engaged. The transmission should be in neutral (N), parking brakes engaged and wheel chocks properly positioned before beginning the engagement process..



CAUTION

Failure to engage parking brakes and/or position wheel chocks could result in unexpected chassis movement which could cause bodily injury or property damage.

2. Start engine and allow it to idle. Let chassis air build to the maximum 120psi.
3. Transfer Case Engagement. Methods of engagement vary with the chassis transmission and transfer case equipment. Select the section below that matches the configuration of the unit being operated
 - a) Manual Transmission with Manual Shift or Air Shift Transfer Case.
 - i) Fully depress the clutch pedal.
 - ii) Shift transmission into high range.
 - iii) Depress clutch and select the proper forward gear which is 1:1 gear ratio. For the standard 10 speed transmission, use 9th gear.
 - iv) If equipped with an air shift transfer case, locate the valve or switch (respectively) labeled "Rear Axle", "RAD", or "Vacuum Pump" between the driver's and passenger seats or on the instrument panel. Move the valve or switch to the "engaged" position.
 - v) If equipped with a manual cable shift transfer case, locate the lever between the driver's and passenger seat labeled "Rear Axle". Pull

- up on the lever until it is fully engaged. It may be necessary to feather the clutch in order to get full engagement. A light will come on indicating the rear axle is disengaged.
- vi) Slowly release the clutch. The main driveline will be turning at this time, but not the liquid ring vacuum pump.
- b) Automatic Transmission with Manual Shift or Air Shift Transfer Case.
 - i) Confirm the transmission gear selector is in neutral (N). Never shift the transfer case with the transmission in drive (D) or reverse (R) or damage will occur.
 - ii) If equipped with an air shift transfer case, locate the valve or switch (respectively) labeled "Rear Axle", "RAD", or "Vacuum Pump" between the driver's and passenger seats or on the instrument panel. Move the valve or switch to the "engaged" position.
 - iii) If equipped with a manual cable shift transfer case, locate the lever between the driver's and passenger seat labeled "Rear Axle". Pull up on the lever until it is fully engaged. If it does not fully engage, it will be necessary to pull up lightly on the lever while momentarily placing the transmission gear selector in drive (D). Immediately return the transmission gear selector to neutral (N). A light will come on indicating the rear axle is disengaged.
 - iv) Place the transmission gear selector in drive (D). The main driveline will be turning at this time, but not the liquid ring vacuum pump.
-  **CAUTION**

Make sure no one is near the end of the vacuum hose and that the vacuum relief door is open before engaging the vacuum pump. Failure to do so could cause personal injury.
4. Check the water level in the water supply tank. Never run the vacuum pump without water. Only clean water is to be used as seal medium. 'Anti freeze' may be added to the seal water to prevent systems from freezing up.
 5. Do not start the liquid ring vacuum pump when the pump is full of water. The green "Liquid Ring Water Sensor" light on the main control panel must be off.
 6. At the main control panel turn the "Vac Pump" switch ON.
 7. Open the water supply valve. Water will start flowing into the vacuum pump and the green "Liquid Ring Water Sensor" light will turn on and the vacuum pump will start turning.
 8. At the main control panel turn the "Remote Throttle" switch ON.
 9. Push the "Throttle" switch up to increase the engine RPM and the vacuum pump RPM. To maintain proper lubrication, do not run the vacuum pump slower than 500 RPM. Never exceed 750 RPM with the vacuum pump engaged. Do not run the engine slower than 1000 RPM. Do not run the engine slower than 1200 RPM when Bag Pulsing is ON.
 10. When it is time to vacuum material, close the vacuum relief door by operating the switch on the control panel, wireless remote, or pendant. The vacuum relief door switch on the main control panel must be in the "closed" position for the vacuum relief door to close.
 11. When done vacuuming, open the vacuum relief door. Reduce the engine speed to idle and turn "Remote Throttle" OFF.
 12. Close the water supply valve.
 13. Turn the "Vac Pump" switch OFF. This will turn on the purge pump for about 60 seconds or for about 30 seconds after the green light goes out.
 14. Transfer Case Disengagement.
 - a) Manual Transmission with Manual Shift or Air Shift Transfer Case.
 - i) Fully depress the clutch pedal and wait five to ten seconds for the driveline to stop turning.
 - ii) If equipped with an air shift transfer case, locate the valve or switch (respectively) labeled "Rear Axle", "RAD", or "Vacuum Pump" between the driver's and passenger seats or on the instrument panel. Move the valve or switch to the "disengaged" position.
 - iii) If equipped with a manual cable shift transfer case, locate the lever between the driver's and passenger seat labeled "Rear Axle". Push down on the lever until it is fully engaged. It may be necessary to feather the clutch in order to get full engagement. A light will go out indicating the rear axle is engaged.
 - iv) Shift transmission into neutral and slowly release the clutch. The main driveline should not be turning at this time.

- 2
- b) Automatic Transmission with Manual Shift or Air Shift Transfer Case.
- i) Place the transmission gear selector in neutral (N). Never shift the transfer case with the transmission in drive (D) or reverse (R) or damage will occur.
 - ii) If equipped with an air shift transfer case, locate the valve or switch (respectively) labeled "Rear Axle", "RAD", or "Vacuum Pump" between the driver's and passenger seats or on the instrument panel. Move the valve or switch to the "disengaged" position.
 - iii) If equipped with a manual cable shift transfer case, locate the lever between the driver's and passenger seat labeled "Rear Axle". Push down on the lever until it is fully engaged. If it does not fully engage, it will be necessary to push down lightly on the lever while momentarily placing the transmission gear selector in drive (D). Immediately return the transmission gear selector to neutral (N). A light will go out indicating the rear axle is engaged. The main driveline should not be turning at this time.

15. At the conclusion of work, the vacuum pump is to be drained of all seal water. Close the water supply valve and open all vacuum pump drain valves.

16. If there is a danger of frost (freezing) or if the system is to be left idle for a period, the entire vacuum pump system is to be totally drained, including the seal water tank and all associated pipe work. Valves and cocks are to be left open during that period.

Liquid Ring Error Light

The Liquid Ring vacuum pump system includes sensors and a control system that protects against common errors or issues. When an error is detected the vacuum pump will be deactivated and the amber or red colored Error Light will turn on or flash depending on the error that has been detected.

- Light Flashing Slowly (1 flash per second) = The vacuum pump went dry while running. To correct this error: Reduce engine speed to idle, Turn off the "Vac Pump" switch, Close the water supply valve, Fill up the water supply tank, and Restart the process at step 4 above.
- Light Flashing Fast (3 flashes per second) = The vacuum pump was flooded before starting. To correct this error: Close the water supply valve, Turn the "Vac Pump" on then off to restart the purge pump, and Restart the process at step 4 above.
- Light ON = The transmission is in the wrong gear and the driveshaft is turning too fast or too slow; Or the E-Stop is engaged.

Cooling Air Injection Valve

The Supersucker Liquid Ring is equipped with a standard cooling air injection device (aka intercooler system) to protect the vacuum pump from overheating. The vacuum pump is rated for full vacuum, but will warm up to as much as 60°F above ambient temperature depending on the operating vacuum level. Clean and inspect this device for proper operation if operating temperatures exceed this value

Seal Water Contamination

The seal water (aka process water) that seals and cools the liquid ring vacuum pump may become contaminated during use. Contaminated seal water and lubricants are to be disposed of in accordance with the applicable environmental guide lines.

Vacuum Relief Valves

Super Products offers two (2) types of vacuum relief valves. The in-line "T" type vacuum relief valve is delivered with the unit as optional equipment and its operation is described in this procedure. The remote operated vacuum relief valve is standard. It consists of a hinged door which is opened/closed by a pneumatic cylinder. The cylinder is controlled by the operator at the control panel or the pendant remote or the wireless remote. Its operation is also described in this procedure.

- Always use emergency "T" type relief valve, except as noted in item six (6) below.
- When safety person is used, make sure he/she is in full view of person(s) at end of vacuum hose.
- When working close to end of hose, wear tight fitting clothes. Keep shirts and jackets closed so that shirt tails and jacket tails will not be pulled into end of hose. Remove loose fitting jewelry such as bracelets and necklaces unless they are under tight fitting clothing.
- Do not use hand or foot to remove obstructions from end of hose.
- Keep all body extremities and clothing from end of hose.
- The only time the emergency "T" type relief valve is not required is when the operator is working vertically off the boom hose. In this case only, the operator should use the remote operated relief valve as described elsewhere in this manual section. Otherwise, use only the emergency relief valves approved by Super Products. Failure to comply with this requirement could cause bodily injury, for which Super Products will not be responsible.

Operation Instructions - "T" Type Vacuum Relief



WARNING

See section on "Testing of T" type vacuum relief valve before using due to possible personal injury or death.



CAUTION

If person operating at end of vacuum hose is in a confined space or for any other reason cannot easily reach pull cord on their safety belt, there must be a safety person(s) wearing safety belt with pull cord attached who must be in a position to view person(s) working at end of vacuum hose.



WARNING

If vacuum relief valve is not working properly, personnel should not be allowed in work at end of vacuum inlet hose due to possible injury or death.



WARNING

See section on testing of remote operated vacuum relief valve before using due to possible personal injury or death.



WARNING

Never move close to the end of any vacuum hose unless the safety person has the remote and is in a position to observe all operators. Failure to comply with this could result in serious personal injury or death.



WARNING

If vacuum relief valve is not working properly, personnel should not be allowed to work at end of vacuum hose due to possible personal injury or death.



CAUTION

Never work beyond the distance from the truck that the wireless remote control was previously tested at. Failure to comply could result in equipment not properly operating.

Suction Line Connections

Super Products hose-to-hose and hose-to-tube connections provide for fast set up of suction lines. This is achieved by providing loose fitting male and female ends of each length of suction hose or Supertube aluminum suction tube. The loose fit allows for quick and easy assembly. An O-ring gasket is placed over the male coupler before assembly to female coupler to eliminate air leaks. A locking secures the ends together and snaps overcenter.

This coupler system is used on all four (4), six (6) and eight (8) inch diameter suction line systems. In determining the best overall suction line set-up, the following facts should be considered:

1. Larger hose diameters provide greater loading rates.
2. Loading rates are reduced as conveying distance is increased.
3. Physical effort required relative to hose size:
 - a. Four (4) inch diameter hose and smaller can be handled by one (1) man with minimal rest periods.
 - b. Six (6) inch diameter hose can be handled by one man but requires frequent rest periods. Normally two (2) men will alternate or multiple smaller hoses are used at work area.
 - c. Eight (8) inch diameter hose can not be handled by the average man without great physical exertion. Normally fed with shovels, wheel barrows or multiple smaller hoses.

4. The chart below gives the recommended normal particle size range for each hose diameter. Occasional particles larger than those indicated below can be handled.

Hose Diameter	Particle Size
8"	3"
6"	2"
4"	1"
2.5"	0.5"

5. Bends reduce loading rates significantly. Straight runs with a minimum number of long radius bends made with smooth bore suction hose are the most efficient.

Suction Line Set Up Guidelines

1. Install relief valve as shown in this manual.
2. Use largest diameter suction line possible. Performance is affected by material handled, product model, and crew size. Use Supertube for straight runs and hose for bends and material pick-up.
3. When using Y connectors, branch from eight (8) or six (6) inch diameter main suction line to multiple four (4) inch hoses whenever possible. An average person will achieve higher loading rates over the period of a full shift using four (4) inch diameter suction hoses.
 - a. Minimize length of all suction lines.
 - b. Minimize number of bends in all suction lines, use of Supertube reduces excess bends.
 - c. Install permanent access ducting in area to be cleaned frequently.

Loading Rates

The loading rate and maximum suction line length are influenced by numerous factors, such as air velocity, material density, particle size, particle shape, coefficient of friction, moisture content, altitude, operator's skill, operator effort and many others. For this reason it is impractical to accurately state the performance characteristics of any industrial vacuum loading machine.

It is practical, however, to approximate the performance for a typical, dry, granular, free-flowing material if it is recognized that such approximations are meant to be relative indicators rather than absolute quantities.

The following table expresses the maximum typical loading rate possible with the SUPERSUCKER® for various hose diameters and lengths. These values have been confirmed by testing and represent only the rate at which material is loaded into the collector body. They do not consider setup and teardown operations, hauling, and dumping the payload, and any factors related to the performance of the operator. The values shown must be factored down to estimate production capabilities over more significant periods of time, such as an operating shift.

2

Table 2-1: Maximum Typical Loading Rate (Pound/Minute)

		Class A Materials			Class B Materials			Class C Materials		
Air Velocity (ft/min)		5000 ft/min			7500 ft/min			1000 ft/min		
Suction Line										
Smooth Bore Diameter	Length (Inches x feet)	Friction Loss ("Hg)	Roots 1125 Blower RPM	Max Loading Rate (lbs/min)	Friction Loss ("Hg)	Roots 1125 Blower RPM	Max Loading Rate (lbs/min)	Friction Loss ("Hg)	Roots 1125 Blower RPM	Max Loading Rate (lbs/min)
8	100	0.8	900	1950	1.2	1200	1490	1.9	1350	880
8	200	1.5	900	1680	2.4	1200	1320	3.8	1400	740
8	300	2.3	900	1490	3.6	1200	1160	5.7	1400	610
8	400	3.0	900	1340	4.8	1200	1050	7.6	1450	470
8	500	3.8	900	1180	6.0	1200	910	9.5	1500	330
6	100	1.0	900*	1160	1.9	900*	850	3.0	900	550
6	200	2.0	900*	990	3.8	900*	720	6.0	900	410
6	300	3.0	900*	830	5.7	900*	580	9.0	950	280
6	400	4.0	900*	720	7.6	900*	470	12.0	950	170
6	500	5.0	900*	630	9.5	900*	360	15.0	1000	80
4	100	1.6	900*	550	2.7	900*	390	4.5	900*	220
4	200	3.2	900*	470	5.4	900*	300	9.0	900*	140
4	300	4.8	900*	410	8.1	900*	220	13.5	900*	60
4	400	6.4	900*	360	10.8	900*	180	18.0	900*	---
4	500	8.0	900*	300	13.5	900*	80	22.5	900*	---

900* Run blower at 900 RPM and partially open the manual relief valve to reduce air velocity to reduce carry over

MATERIAL	CLASS	MATERIAL	CLASS	MATERIAL	CLASS
Alumina	B	Fly Ash	A	Salt	B
Borax	B	Graval	B	Sand	B
Cement	B	Gypsum	B	Sawdust	A
Coal	A	Iron Ore	C	Steel Shot	C
Coke	A	Kish	B	Water	B
Copper Ore	B	Lime	B	Wheat	B
Copper Concentrate	C	Limestone	B	Wood Chips	A
Cork	A	Mill Scale	C		
Corn	B	Oats	A		

Control System Operation

Control Panel



Figure 3-1

The control cabinet contains a number of gauges and controls. Standard gauges include:

- Vacuum gauge - indicates vacuum at Vac pump
- Vac Pump tachometer/hourmeter
- Vac Pump exhaust temperature Gauge
- Throttle Enable Switch
- Throttle Fast/Slow Switch
- Vacuum Relief Switch
- Bag Pulsing Switch
- Vibrator Switch
- Panel Light Switch

Bag Pulsing

Bag pulsing is a system that momentarily reverses blasts of air thru the filter bags to clean them. The system is turned on and off by a switch on the control panel. Bag pulsing should be turned on whenever material is being vacuumed up. If the bags are dirty, the pulsing system can be used to help clean them in over the road travel.



WARNING

Ensure bag pulsing is turned off before opening any access or clean out door. Failure to do so can result in personal injury.

The Bag Pulsing system is preset with an OFF Time of 20 seconds and an ON Time of about 0.6 seconds. With the vacuum pump off and the bag pulsing on you should be able to feel air pulsing out of the bags by reaching into the driver side dust bin. Secondly, the ON and OFF settings are important to let the chassis air compressor catch up between pulses. The chassis air must reach the maximum limit every few minutes to pop open the dryer and unload the condensation. If this does not happen the engine RPM should be increased (typically 1200 RPM minimum). If the air dryer does not pop open often every few minutes water will build up in the air system and foul or damage the air system equipment.

Transfer Case Shifter Control



Figure 3-2

The shifter is the two (2) lever control located on the cab floor next to the driver's seat. The left, or forward, handle engages and disengages the rear axles. There is a neutral position between the engagement and disengagement positions. The right lever engages and disengages the vacuum pump. For more detailed instructions, refer to the Vacuum Pump Operation section of this manual.



CAUTION

When the rear axles are disengaged and the light on the instrument panel in the cab is illuminated, the hydraulic pump is engaged.

Control Valves



Figure 3-3

The control valves operate all of the hydraulic functions on the Supersucker. They are located on the left hand side of the unit behind the cab. The valve handles actuate the following. The front handle raises and lowers the collector body. The next handle opens and closes the tailgate. The third handle engages and disengages the tailgate latches. Pushing the handles in lower the collector body, close the tailgate and latch the tailgate. Conversely, pulling the handles toward you raise the collector body, open the tailgate and unlatch the tailgate.

Any additional valves, other than the three (3) basic functions, operate options. All options are operated by pulling the valve handle towards you; the valve spool detent will hold the spool.



CAUTION

All valve functions and operations are identified. Make sure you understand all functions and operations before operating unit. Failure to do so could result in equipment damage or personal injury.

Dumping Payload

CAUTION

Dumping dry, dusty materials must be at an approved site or properly treated.

1. Position unit and set parking brakes.

Manual Transmission. With the engine at idle, depress and hold the clutch pedal. Pause momentarily four (4) to five (5) seconds, disengage the rear axles (this engages the hydraulics). Shift transmission to second highest forward gear.

Automatic Transmission. With engine at an idle and transmission in neutral, disengage the rear axle, engage the vacuum pump, and place the transmission in "Drive". The transmission will automatically select the direct drive (1:1 ratio) gear.

2. Do not stand behind or to sides of tailgate when opening tailgate or dumping body.
3. Open side chute doors on both sides of body.
4. At control station, move tailgate latch lever to open position. Release when unlocked.

CAUTION

Be sure the tailgate latch is open before opening the tailgate. Failure to do so may result in damage to the equipment.

5. Move tailgate lever to open position and release when fully open.
6. Move body hoist lever to raise position until cylinder is fully extended.

DANGER

Keep the body and boom (optional) away from overhead lines to prevent electrocution. Use an observer and make allowances for operator error, machine deflection, and overhead line swaying. Improper operation will cause serious injury or death.

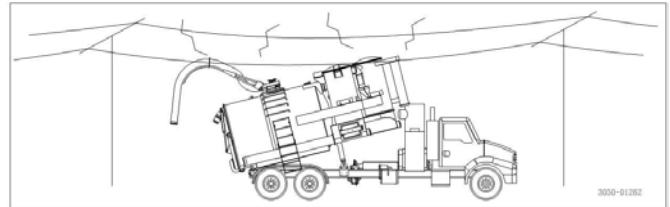

Figure 3-4

7. Use vibrator, if so equipped, intermittently as required, to aid in discharge of material. Continuous use of vibrator may damage unit.
8. After load has completely discharged from body, move body hoist lever to lower position until body returns to full down position.
9. Close and latch both side chute doors.
10. Brush and scrape off any accumulated dirt or residue on and around tailgate gasket and tailgate latches. A tool similar to a putty knife may be desirable to remove sticky material.

WARNING

Ensure tailgate prop is in place before going under the tailgate.

CAUTION

Ensure the tailgate latch is open before closing tailgate. Failure to do so may result in damage to the equipment.

11. Lower tailgate and lock closed.
12. Reverse step #1 above.

NOTES

Baghouse filter condition should be inspected regularly. Actual condition of the filters will depend on the material being conveyed through the system. Refer to maintenance schedule for any further information.

Body Prop Support



DANGER

Always position body prop support in proper position before entering any areas beneath body. Failure to do so could result in personal injury or death.

1. Raise body sufficiently to allow body support to be swung into position.
2. Remove body support hold down and swing body support into support position.
3. Slowly lower body until body contacts body support.
4. To remove body prop support, reverse above procedure.

If there are any questions on how to implement the above, contact Super Products prior to starting the job. Super Products will not be responsible for any damage or injuries if the above procedures are not completely followed.



Figure 3-5

Tailgate Prop



DANGER

Always position the tailgate props in the proper position before entering any area beneath the debris body tailgate or entering the debris body. Failure to do so could result in serious injury or death.

The following procedure should be used:

1. Ensure the tailgate area is clear of people and obstructions.
2. Unlatch and fully open tailgate.
3. The tailgate prop should automatically engage as the tailgate is being raised and will make a sound as the prop rod falls into the teeth of the prop mechanism. Inspect for proper engagement or damage if the sound is not heard.
4. Ensure area is clear of people and obstructions before lowering the tailgate.
5. Disengage the tailgate prop by pulling down on the prop disengage handle. Note, the tailgate may have to be raised slightly to take force off the prop before disengaging the prop.
6. Fully lower and latch the tailgate.

Over The Road Operation

Always secure the baghouse and separator covers in the closed position with rubber hold downs provided before traveling over the road.



WARNING

Failure to secure baghouse and separator covers in the closed position before traveling over the road may result in opening of the covers under some road, wind, and speed conditions. In the open position, covers may contact overhead obstructions and separate from the Supersucker body causing severe personal injury or death.

Electric Vibrator

The following precaution should be followed whenever operating the vibrator. Failure to observe these precautions could result in damage to the equipment.



CAUTION

Vibrator should be operated only when the dump body is raised. Operating the vibrator with the dump body lowered can result in damage to the vibrator or vehicle.



CAUTION

Continued operation of the vibrator when the vehicle is not running will eventually drain the battery. Vibrator will not deliver full thrust when operated without the battery fully charged.



CAUTION

The vibrator is designed to be operated on an intermittent duty cycle basis only. Three (3) to seven (7) seconds should loosen most struck materials.

Operation of Vibrator

1. Inspect vibrator to ensure firm mounting and good electrical connections.
2. Raise the dump body to the angle desired.
3. Engage the toggle switch for three (3) to seven (7) seconds to allow time for all materials to become discharged. The vibrator is designed for intermittent use only and should be operated in that manner. The switch is a momentary contact switch, and will operate the vibrator as long as the switch is depressed.
4. To turn vibrator off, release the toggle switch.

Boom Operation (Optional)



Figure 3-6

The Supersucker can be equipped with a full hydraulic power boom. This boom includes a pendant with the following functions:

- OPEN - Opens the vacuum vent door
 - CLOSE - Closes the vacuum vent door
 - IN - Retracts the boom extension
 - OUT - Extends the boom extension
 - LEFT - Rotates the boom to the left
 - RIGHT - Rotates the boom to the right
 - UP - Raises the boom
 - DOWN - Lowers the boom
1. Start truck engine and allow to idle. Make sure parking brake is set and wheel chocks positioned. Place transmission into neutral.



CAUTION

Failure to do so could result in truck rolling forward or backward resulting in potential personal or property damage.

2. Turn the "Throttle Enable" switch on the instrument panel to "ON". The boom is powered off the main hydraulic system by pulling a control lever labeled "BOOM". The main PTO driven hydraulic system does need to be engaged to operate the boom.
3. Plug the Boom Pendant into the receptacle near the left rear mudflap. Lift the cover and insert the male plug end making sure that the key on the plug matches the notch on the receptacle. By operating the properly marked buttons, you can perform any of the functions outlined above. When done with the pendant, make sure you unplug it and properly store it before moving the truck.
4. Make sure the area is clear of obstructions and people before operating boom



CAUTION

When swinging boom, make sure you are aware of where all other personnel in the area are and that swing path for the boom will not hit any obstruction. Failure to comply could result in personal injury and/or property damage.



DANGER

When operating the boom, make sure you watch for overhead electrical wires or anything else which could result in personal injury or property damage.

5. To remove the boom from the transport position, first push the "UP" button to raise the end of the boom about 3 feet to clear boom cradle and other parts of the Supersucker. Then push the "RIGHT" button to rotate the boom 90° to the side of the truck.
6. Connect required intake tubes onto intake hose. Make sure gaskets are positioned on couplings and over center clamp is fully closed. Use shortest possible length of tubing to ensure most direct route.



WARNING

Return boom to cradle before dumping payload or moving truck. Failure to do so could cause excessive boom wear or failure resulting in severe personal injury or death.

7. When finished using the boom, remove intake tube and hoses, and position the boom to the transport position before moving the truck. To return the boom to the transport position:
 - a. Raise the boom to be about 3 feet above horizontal.
 - b. Fully extend the boom.
 - c. Rotate the boom "Left" until it stops.
 - d. Lower the boom until it contacts the boom cradle.

Water System (Optional)

The Supersucker also has an optional water system for cleaning or hydroexcavation. This consists of water tanks saddled along the side of the collector body and a water pump. This pump is hydraulically driven and includes flow controls to regulate the output of the water pump. The pump is protected by a relief valve which limits the maximum pressure.



WARNING

Never exceed the pressure rating of your system. Failure to comply could result in personal injury or property damage.

Sludge Pump (Optional)



Figure 3-7

The sludge pump option is used to offload liquids and slurries in a controlled manner. The Hydraulically powered sludge pump can be used either during or after vacuum operations. Depending upon the characteristics of the material, the vacuum level in the debris body and distance from the pump, material can be pumped to higher elevations than the truck is located. Under high vacuum levels it may not be possible to pump some materials.

Operation of Sludge Pump

1. Inspect sludge pump to ensure firm mounting and good hydraulic connections.
2. Connect any necessary discharge hoses to the sludge pump before starting pump.
3. Open the gate valve located between the body and the sludge pump.
4. Move hydraulic control valve handle, located on the main hydraulic control valve at the operator's station, to the "on" position. The valve is detented in the "on" position and will stay in this position until pushed back to the "off" (centered) position.
5. To stop the sludge pump, close the gate valve between the body and sludge pump then move the hydraulic control valve handle to the "off" (centered) position.
6. Disconnect discharge hoses (if used).
7. Run the sludge pump briefly (15-30 seconds) to discharge material remaining in pump housing.

8. Before storing in freezing temperatures, open the gate valve between the debris body and sludge pump, raise the tailgate to the horizontal position and run the sludge pump briefly to assure that all liquid has been removed from the pump housing.



CAUTION

Failure to properly drain sludge pump may result in damage to pump.

Mobile Ground Verification (MGV) System (Optional)

Vacuum trucks and tank trucks, including their hoses and hose connections, are susceptible to static charge accumulation during the transfer of product into or out of the truck's containment system. This accumulation of static charge is equivalent to a hidden source of ignition and if discharged as a static spark can lead to the ignition of the product or the atmosphere in which the truck and material handling team is operating. To mitigate the risk of incendive static spark discharges the API standard 2219: Safe Operation of Vacuum Trucks in Petroleum Service recommends that vacuum truck operators transferring flammable and combustible product in hazardous locations must fully ground the truck prior to any other task in the transfer operation by connecting the truck to a "proven ground source". The Earth-Rite II MGV is designed to enable operators to establish safe grounding of their vehicle in accordance with this standard.

The Earth-Rite II MGV system performs two system checks which ensures the vehicle can dissipate static charges for the duration of the transfer process.

1. Static Ground Verification - The MGV system ensures the connection resistance of the object that is identified as the ground source to earth, is low enough to safely dissipate static charges from the truck.
2. Continuous Ground Loop Monitoring - When the Static Ground Verification process is confirmed, the Earth-Rite II MGV system continuously monitors the connection resistance of the truck to this verified grounding point for the duration of the transfer process. This connection resistance must be maintained at 10 Ohms (or less) for the duration of the transfer process.

When the Static Ground Verification and Continuous Ground Loop Monitoring checks are positive, a cluster of green LEDs pulse continuously informing the operator that the truck is securely grounded.

When a static ground connection fails to be established or maintained LEDs turn red and the vacuum relief door is opened thereby stopping the vacuuming process and alerting the operator.

A manual override switch is provided on the main control panel to deactivate the MGV system when vacuuming materials that do not require static charge dissipation



Figure 3-8



DANGER

Read the Hydrocarbon Waste Recovery section of this manual before vacuuming hydrocarbon materials.

Liquid Ring Control Panel (Optional)

The Liquid Ring control cabinet contains a number of gauges and controls. Standard gauges include:

- Vacuum gauge - indicates vacuum at Vac pump
- Vac Pump Tachometer/Hourmeter
- Liquid Ring Water Sensor Indicator ILght
- Liquid Ring Error Indicator ILght
- Liquid Ring Water Temperature
- Throttle Fast/Slow Switch
- Vacuum Relief Switch
- Bag Pulsing Switch
- Vibrator Switch
- Vac Pump ON/OFF Switch
- Throttle Enable Switch
- Ground Verification ON/OFF Switch
- Panel Light Switch



Figure 3-9

High Dump Operation (Optional)

The high dump feature allows payload to be emptied directly into a dumpster, roll-off box, or other similar container of 60 inch height or less. The high dump feature also allows the payload to be dumped normally when the high clearance of this feature is not required. In addition, when the Supersucker is equipped with the high dump feature, the main hydraulics are powered from a transmission mounted PTO. The PTO mounted hydraulic pump allows the Supersucker dump body to be positioned above the receiving container without repeatedly engaging and disengaging the transfer case.



WARNING

Operate the high dump function on solid, level ground with calm wind conditions only. Operation of high dump on unstable ground or in high wind conditions may cause Supersucker to become unstable resulting in serious personal injury or death.

Note: To dump without using the high dump feature refer to the standard payload dumping procedure located elsewhere in this manual.

Dumping of Payload with High Dump Function

1. Position Supersucker as close as possible to dumpster. Place transmission in neutral and set parking brake.
2. Engage hydraulic pump PTO. See procedure elsewhere in manual.
3. Raise body to approximately 10°.
4. Raise subframe slightly and release subframe support latches.
5. Raise subframe fully. If subframe will not raise, increase height of body until subframe will raise.
6. Confirm that both subframe supports are centered above their guides. Lower subframe until subframe supports contact truck frame. DO NOT POWER DOWN.



CAUTION

DO NOT POWER DOWN SUBFRAME OR BODY WITH SUPPORTS IN PLACE. EQUIPMENT DAMAGE AND/OR SERIOUS PERSONAL INJURY MAY RESULT.



7. Back Supersucker to dumpster. Place transmission in neutral and set parking brake.
8. Do not stand behind or to sides of tailgate when opening tailgate or dumping body.
9. Unlock tailgate latches.



CAUTION

Be sure the tailgate latch is open before opening the tailgate. Failure to do so may result in damage to the equipment.

10. Fully open tailgate.
11. Raise body until cylinder is fully extended or until desire dumping angle.



DANGER

Keep the body and boom (optional) away from overhead lines to prevent electrocution. Use an observer and make allowances for operator error, machine deflection, and overhead line swaying. Improper operation will cause serious injury or death.

12. Use vibrator, if equipped, intermittently as required, to aid in discharge of material. Continuous use of vibrator may damage unit.
13. After load has completely discharged from body, lower body until body stops, or is approximately horizontal.

14. Move Supersucker away from dumpster. Place transmission in neutral and set parking brake.
15. Brush or scrape off any accumulated dirt or residue from on or around tailgate gasket and side chute doors.



CAUTION

Ensure the tailgate latch is open before closing the tailgate. Failure to do so may result in damage to the equipment.

16. Lower tailgate and lock closed.
17. Raise subframe fully.
18. Swing and latch subframe supports in the stowed position.
19. Lower subframe completely.
20. Lower body completely.
21. Disengage hydraulic pump PTO. See procedure elsewhere in manual.



WARNING

Always use subframe supports when working under raised subframe. Failure to do so may result in serious personal injury or death.

Lubrication and Maintenance

General Information

People who maintain this unit should have a basic understanding of the equipment and normal sequence of operation. Refer to other sections of this manual.

When any repairs or adjustments are made to this unit, extreme care should be taken and all safety precautions and decals observed.

Preventive maintenance routines keep the equipment in proper working condition. Preventive maintenance is not only desirable, but is necessary, since scheduled inspection insures continued trouble free operation of the equipment. It also prevents, or at least detects, at an early stage mechanical, hydraulic, or electrical troubles that might otherwise develop into equipment malfunction.

Preventive Maintenance Instructions

We urge you to protect your investment by servicing it according to the maintenance schedule listed on the following pages. Regular maintenance will insure maximum unit performance, long unit life, safety, reliability, and full warranty protection.

Each maintenance item is numbered and is described on the pages following the schedule.

Lubrication Recommendation Chart

Table 4-1:

Component	Lubricant	Capacities
Grease	Super Products Spec 3060-00023 White Lithium	—
Hydraulic System	Super Products Spec 3060-00045 Chevron Rando HD Premium Oil MV	2.5 Gallons
Transfer Case	Super Products Spec 3060-00044 Chevron Clarity Synthetic Machine Oil ISO 150	12 Quarts
Rotary Lobe Vacuum Pump	Super Products Spec 3060-00044 Chevron Clarity Synthetic Machine Oil ISO 150	5 Quarts
Liquid Ring Vacuum Pump	Mineral (non-synthetic) Motor Oil Type SAE 15W40	12 Quarts
Liquid Ring Transfer Case	Super Products Spec 0041276 BP Aufran ATF Tes-295 Oil	13 Quarts
Water Pump	Super Products Spec 3060-00044 Chevron Clarity Synthetic Machine Oil ISO 150	
Trash Pump	Super Products Spec 3060-00005 Automatic Transmission Fluid Type A Dexron 3	

Maintenance Schedule

	DAILY	WEEKLY	MONTHLY	EVERY 1,000 HOURS OR YEARLY
BOOM				
Debris Body	Clean			
Tailgate and Gasket	Clean			
Float Ball and Seal	Clean			
Boom Cannon	Clean			
Transition Duct	Clean			
Separators	Clean			
Seperator House	Clean			
Bags	Clean			
Baghouse		Inspect		Replace as Necessary
Vacuum Chamber Screen	Clean			Replace as Necessary
Vacuum Chamber	Clean			
Tailgate Latches and Hinges	Clean			
Body Pivot		Lubricate		
Body Lift Cylinder	Inspect	Lubricate		
Make/Brake Gasket		Inspect		
Clean Out Doors	Clean	Lubricate		
Bag House Door	Clean		Inspect	
Pulsing System			Inspect	
Boom Rotation (if equipped)	Inspect	Clean		
Nuts and Bolts		Inspect/Tighten		
Dust Chute	Clean	Inspect	Tighten	
ELECTRICAL SYSTEM				
Fuses			Inspect	Replace
Lights	Inspect			Replace
Boom Pendant Plug and Receptacle (optional)		Inspect	Clean/Lubricate	
HYDRAULIC SYSTEM				
Hydraulic Oil		Inspect		Replace
Hydraulic Filter			Inspect	Replace
Hoses and Fittings		Inspect		

4

	DAILY	WEEKLY	MONTHLY	EVERY 1,000 HOURS OR YEARLY
POWER UNIT				
Vacuum Pump Oil Level	Inspect			Replace
Water Pump Oil Level	Inspect			Replace
Vacuum Vent Door		Inspect		
Drain Valves		Inspect	Clean	
Nuts and Bolts		Inspect/Tighten		
Transfer Case		Inspect		Replace
Driveshafts			Inspect/Lubricate	
LIQUID RING VACUUM PUMP				
LR Vacuum Pump Oil Level	Inspect			Replace
LR Vacuum Pump Oil Breather			Inspect	Clean
Intercooler Screen	Inspect			Clean
Intercooler Check Valve			Inspect	
Drain Valves		Inspect	Clean	
Nuts and Bolts		Inspect/Tighten		
LR Transfer Case Oil Strainer				Clean or Replace
LR Transfer Case Oil		Inspect@dipstick		Replace

Maintenance Items

1. Debris Body: Clean and inspect for cracking, leaks or wear.
2. Tailgate and Tailgate Gasket: Clean and inspect the tailgate for cracks, leaks or wear. Clean and inspect the gasket for cuts, cracks, wear or for looseness in gasket retainer.
3. Float Ball: Clean and inspect the float ball for dents and holes. Clean and inspect the float ball retainer for damage or missing pins.
4. Boom Cannon: Clean and inspect for cracking, leaks or wear.
5. Transition Duct: Clean and inspect for cracks, leaks or wear. Check gaskets on inspection doors for cuts, cracks or wear.
6. Separators: Clean and inspect the separators for cracks, leaks or wear. Check the seals for leaks and check the clamps to insure they are all tight.
7. Separator House: Clean and inspect the separator house for cracks, leaks or wear.
8. Bags: Inspect the bags for cuts or tears. Replace as required. Replace the filter bags every one thousand (1000) operating hours or six (6) months whichever occurs first regardless of apparent condition.
9. Baghouse: Clean and inspect the baghouse for cracks, leaks or wear.
10. Vacuum Chamber Screen: Clean and inspect for cracks, cuts or wear.
11. Vacuum Chamber: Clean and inspect for cracks, leaks or wear. Inspect the drain valve on the bottom of the vacuum chamber for proper operation.
12. Tailgate Latches and Hinges: Lubricate the tailgate latches at grease zerks with standard wheel bearing grease and visually inspect the hinges and latch area for wear or other mechanical problems.
13. Body Pivot: Lubricate the body pivot at the rear of the truck and at the grease zerks with standard wheel bearing grease. Visually inspect the hinges and pins for wear or other mechanical problems.
14. Body Lift Cylinder: Lubricate the body lift cylinder pivot points at the grease zerks with standard wheel bearing grease. Visually inspect the pivot points for cracks or wear and the lift cylinder for seal leakage or physical damage.

LUBRICATION AND MAINTENANCE

15. Vacuum Pump: Check oil level daily before start up. Check the level at both ends of the vacuum pump using the sight eyes. Top off as necessary. Initially change oil in vacuum pump at both ends after first month of use and then every twelve (12) months or one thousand (1000) hours whichever occurs first.
16. Transfer Case: Check the oil level daily before start up using the sight eye. Top off as necessary. Initially change oil in vacuum pump at both ends after first month of use and then every twelve (12) months or one thousand (1000) hours whichever occurs first.
17. Drive Shafts: Lubricate all the drive shafts at the grease zerks with standard wheel bearing grease. Inspect for loose hardware and any other mechanical problems.
18. Make/Break Gasket: Clean and inspect the make/break gasket at the connection of the body and vacuum chamber for cracks, cuts, tears and leaks. Check to ensure the clamp is tight.
19. Clean Out Doors: Clean and inspect the baghouse and separator house doors for gasket damage and/or leaks. Check the latch and hinges for wear or damage. Check the door adjustment to ensure proper sealing to the body.
20. Baghouse Door: Clean and inspect the baghouse door for gasket damage and/or leaks. Check the hinges, hydraulic cylinders and mounts for wear or damage.
21. Pulsing System: Inspect the pulsing system for air line and fitting leaks. Check the pulsing cycle time and operation of the solenoid valves.
22. Electrical System: Visually inspect all wires, timers, relays, fuses and connections for burns, cracks, damage or corrosion. Clean thoroughly and replace any damaged parts.
23. Boom Pendant Plug and Receptacle: Inspect pendant plug and receptacle for contact and proper alignment. Clean terminals monthly and lubricate with silicone grease if problems arise.
24. Hydraulic System: Inspect all hoses, fittings, valves and cylinders for cracks, damage or leaks.
25. Hydraulic Reservoir: Check reservoir for leaks or damage. Check oil level with the body down and with the tailgate down and latched. Check filter indicator for filter condition. Change oil and filter every twelve (12) months or one thousand (1000) operating hours, whichever occurs first.
26. Hydraulic Filter: Initially replace hydraulic filter after first month of operation, then replace every six (6) months or sooner per the filter condition indicator.
27. Boom Rotation: Lubricate at the grease zerks with standard wheel bearing grease. Inspect for any damage or mechanical problems.
28. Boom: Inspect the boom mechanism and cylinder for damage or mechanical problems. Repair or replace as required.
29. Bolts and Nuts: Check and tighten any loose bolts and nuts.
30. Dust Chute Doors: Clean and inspect the dust chute doors, gaskets and latches for cuts, cracks or damage.
31. Electric Vibrator: The vibrator motors are high efficiency permanent magnet electrical motors. Generally, when brushes require replacement, the rotor also requires replacement. Vibrator bearings are double sealed ball bearings and do not need greasing.

Liquid Ring Vacuum Pump Oil

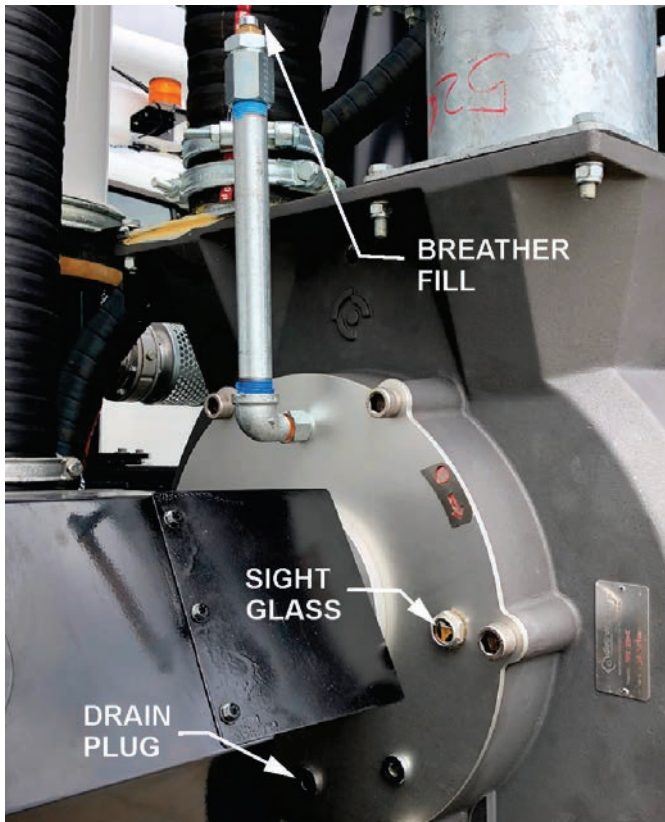

Figure 4-1

Liquid Ring Transfer Case Oil Strainer

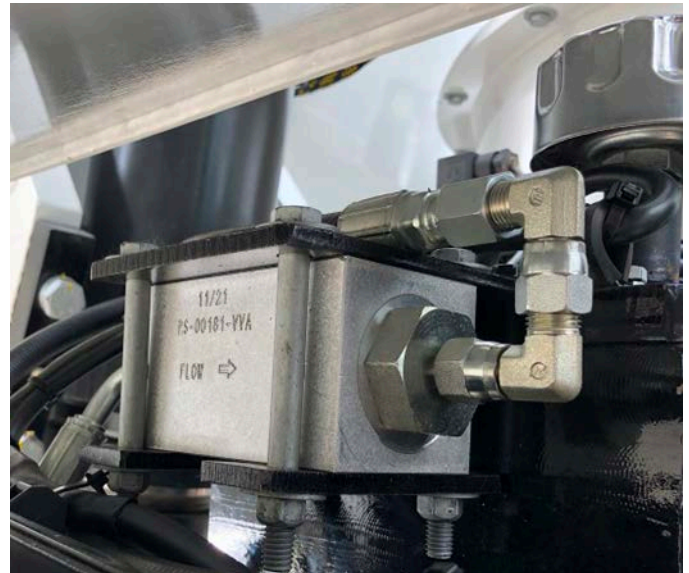

Figure 4-3

Liquid Ring Vacuum Pump Intercooler Screens



Figure 4-2

Troubleshooting

Troubleshooting Overview

This guide is intended as a quick reference to aid operators and technicians in troubleshooting potential issues with the Super Products' Supersucker® Industrial Vacuum Loader.

This guide describes symptoms and lists several probable causes and their solutions. The primary rule of troubleshooting is to check the simple things first; therefore, the probable causes are generally listed in order of simplest to most complex.

Before attempting any repair, read, understand, and follow the operator's manual instructions, warnings, and safety messages.

All repairs should be performed by a qualified technician.

Before attempting any Troubleshooting you must call our Customer Service Representatives at 262-784-7100

The Basic Troubleshooting Process

1. Prepare tools, information, and safety equipment.
2. Define the symptom.
 - What is the problem?
 - When does it occur?
 - When did it work properly?
 - When did it stop working properly?
 - What was done in between those times?
3. Reproduce the symptom.
4. Narrow it down to the root cause.
 - Proceed logically.
 - Check the simple things first.
 - Divide and conquer — rule out what is not the problem. This is especially important to define if the root cause is human error, electrical, hydraulic, or mechanical.
 - Believe your evidence — if all else is eliminated, that which remains must be true.
 - Never assume anything — check it yourself.
 - Check everything — you could have multiple faults.
5. Repair or replace the defective component.
6. Educate and train the operator when it is a case of human error.
7. Verify the symptom is gone.

Table 5-1:

TYPICAL HYDRAULIC FUNCTIONS PRESSURES AND TIMES		
Function	Pressure (psi)	Time (s)
Body Raise	500	35
Body Lower	2000	42
Tailgate Raise	1700	17
Tailgate Lower	750	28
Tailgate Latch/Unlatch	1000	2
Boom Rotation - 90°	300	60
Boom Up	1400	9
Boom Down	600	10
Boom Extend	400	29
Boom Retract	400	21

Mechanical Troubleshooting

Problem	Possible Cause	Remedy
Unit does not draw vacuum: A. Vacuum relief open.	Body full of material (liquid or solid).	Dump load.
	Intake hose restricted or plugged.	Remove obstructions from hose.
	Baghouse filled with material.	Dump load, clean baghouse.
	Ducting in body or baghouse plugged or filled with material.	Clean ducts.
	Screen in vacuum chamber restricted or plugged.	Clean screen.
	Level detector not functioning.	Repair or replace as required.
Unit does not draw vacuum: B. Vacuum relief closed.	Body full of material (liquid or solid).	Dump load.
	Body not completely down.	Lower body.
	Intake hose restricted.	Remove obstruction(s) from hose.
	Tailgate not latched.	Latch tailgate.
	Access doors open.	Close and latch doors.
	Screen in vacuum chamber restricted or plugged.	Clean screen.
	Holes worn in hose or Supertube.	Repair or replace as required.
	Baghouse filled with material.	Clean baghouse.
	Ducting in body or baghouse plugged or filled with material.	Clean ducts.
	Dirty bags, high pressure differential across baghouse	See Symptom - Dirty Bags
	Vacuum Leak:	
	Supertube or hose coupler assembly gasket(s) missing or damaged.	Adjust, repair or replace any missing or leaking gaskets.
	Gasket from baghouse inspection door missing or damaged.	To find leak(s), take unit to a quiet area, cover intake hose, set vacuum pump speed to maintain eight (8) to twelve (12) inches mercury one hundred ten (110) to one hundred sixty-five (165) inches water) operating vacuum. Inspect machine thoroughly for leaks.
	Tailgate gasket damaged or not sealing.	Repair tailgate and/or replace gasket.
	Body to baghouse door seals damaged or not sealing.	Repair door and/or replace seal(s).
Expansion joint between body and vacuum chamber damaged or not sealing	Repair vacuum chamber and/or replace expansion joint.	
Side chute door gaskets damaged.	Repair or replace gasket.	

5

Problem	Possible Cause	Remedy
Dust in vacuum pump discharge: NOTE: Operating while this condition exists could cause significant damage to vacuum pump and void warranty.	Missing or damaged filter bag.	Replace bag.
No hydraulic oil pressure.	Oil pump suction line plugged or hose liner collapsed.	Repair or replace as required.
	Hydraulic pump not engaged.	Engage.
	Low oil level in hydraulic reservoir.	Add oil as required.
Hydraulic oil foamy or milky.	Air in hydraulic oil tank.	Inspect suction hose and fittings from hydraulic oil tank to pump for air leak.
	Water in oil.	Drain all oil in system, replace oil and oil filter.
Low air pressure. Never reaching one hundred (100) PSI, operating while this condition exists will result in plugged baghouse and damaged filter bags. Note: <i>If truck air pressure gauge is less than sixty-five (65) PSI, problem is in truck system or air safety valve on truck air tank connected to Supersucker air system.</i>	Solenoid valve or diaphragm valve on filter stuck open.	Clean, repair or replace as required.
	Faulty compressor or regulator on truck.	Repair or replace.
	Leak in air line, pneumatic valves, cylinders or tanks.	Locate, repair or replace as required.
	Bag pulsing timer cycle too fast.	Adjust interval to ten (10) to fifteen (15) seconds between pulses.
	Defective air pressure gauge.	Replace gauge.
Flooded separator compartment.	Material build-up on or around float.	Remove any material accumulation.
	Float corroded no longer floats.	Replace float.
Dirty bags, high pressure differential across bags.	Filter bag pulsing switch off.	Turn filter bag pulsing switch on.
	Bag pulsing system not functioning: Low air pressure.	See Symptom - Low Air Pressure.
	Pulsing interval out of adjustment.	Adjust on time to momentary pulse (less than one (1) second). Adjust for twenty (20) second intervals between pulses.
	Air hose pinched or broken.	Locate, repair or replace.
	Faulty diaphragm valve.	Replace valve.
	Faulty pilot valve solenoid.	Replace solenoid.
	Faulty pilot valve.	Replace pilot valve.
	No power to timer board.	
	Broken, loose, missing or misplace wire.	Locate, repair or replace..

TROUBLESHOOTING

Problem	Possible Cause	Remedy
Dirty bags, high pressure differential across bags. (Continued)	Faulty pressure switch.	Replace pressure switch.
	Low air pressure.	Replace pressure switch. See Symptom - Low Air Pressure.
	Blown fuse in control panel.	Locate cause, replace fuse.
	Faulty timer board.	Replace timer board.
	Blow Pipes damaged.	Repair and/or replace.
	Permanently blinded bags cannot be cleaned by pulsing system.	Replace bags.
	Material build-up in baghouse compartment.	Dump load, clean out baghouse compartment.
	Excessive material carry-over into baghouse compartment:	
	Body and/or separator house full.	Dump Load
	Body solids level detector malfunction if equipped.	Repair and/or replace level detector.
	Material build-up inside separators.	Remove all accumulated material within separators.
	Vacuum pump speed too fast for material being collected.	Adjust vacuum pump speed.
Leaking tailgate.	Tailgate unlatched.	Latch tailgate.
	Damaged gasket.	Replace gasket.
	Dirt around gasket or mating surface on tailgate.	Clean gasket and remove any material on mating surface of tailgate.
	Damaged gasket retainer or tailgate surface.	Repair or replace.
Tailgate latch will not close	Dirt or material accumulated on collar, shaft, hook or tailgate surface.	Remove all accumulated dirt and material.
	Rollers or shaft binding or frozen.	Lubricate rollers and shaft. Free binding parts.
	Hydraulic oil pressure too low.	Adjust hydraulic relief pressure to two thousand (2000) PSI. See trouble-shooting "no hydraulic oil pressure".
	Hydraulic lines pinched, plugged or broken.	Locate, repair or replace.
Tailgate will not open or close	No hydraulic oil pressure or flow.	See Symptom - No Hydraulic Oil Pressure.
	Hydraulic line pinched, plugged or broken.	Locate, repair or replace.
	Hydraulic cylinders failed.	Replace cylinders.
Hydraulic pump will not engage	Rear axle not disengaged.	Disengage rear axle.
	Transmission not in gear.	Shift to high gear.

5

Problem	Possible Cause	Remedy
Vacuum pump will not engage.	Rear axle not disengaged.	Disengage rear axle.
	Vacuum pump not engaged.	Engage vacuum pump.
	Transmission not in gear.	Shift to high gear.
Vibrator will not vibrate Option.	Loose, broken or misrouted electrical wire.	Locate, repair or replace.
	Faulty solenoid in control panel.	Replace solenoid.
	Blown fuse in panel.	Locate cause, replace fuse.
	Failed vibrator motor.	Repair or replace.
Boom will not raise or lower. Boom Option.	Broken, loose or misrouted electrical wire.	Locate, repair or replace.
	Pinched, plugged or broken hydraulic line.	Locate, repair or replace.
	Low hydraulic oil level in hydraulic power pack.	Fill power pack oil reservoir to proper level.
	Hydraulic oil pressure relief set too low.	Set power pack relief pressure to two thousand five hundred (2500) PSI.
	Faulty solenoid on hydraulic manifold.	Replace solenoid.
	Hydraulic cartridge failed.	Repair or replace.
	Hydraulic cylinders failed.	Replace cylinders.
	Broken, loose or misrouted wire or bad switch in pendant.	Locate, repair or replace.

Electrical Vibrator Troubleshooting

Vibrator malfunctions are often caused by simple, often overlooked problems, such as loose electrical connections. Should problems develop, these items should be checked assuming the vibrator or switch is defective.

Problem	Possible Cause	Remedy
No vibration or low vibrations.	Loose electrical connection.	Check all electrical connections, tighten loose connections. Remove corrosion.
	Cable or wire severed.	Replace or repair cable or wire.
	Switch open.	Close switch (push).
	Defective switch.	Replace switch, check with continuity light.
	Defective motor*.	Replace one or more motors.
Noisy vibrator.	Loose mounting bolts.	Tighten all bolts used in fastening vibrator to mounting plate.
	Loose mounting plate.	Weld mounting plate securely.
	Worn or dry bearings.	Inspect bearings. Replace if worn or dry. Rotate bearing, if it feels rough, replace.

*Note that one motor will not operate the vibrator. Continued attempts to operate with one motor not functioning properly will result in failure of the functioning motor.

Schematic Supersucker Hydraulic System - 0035447

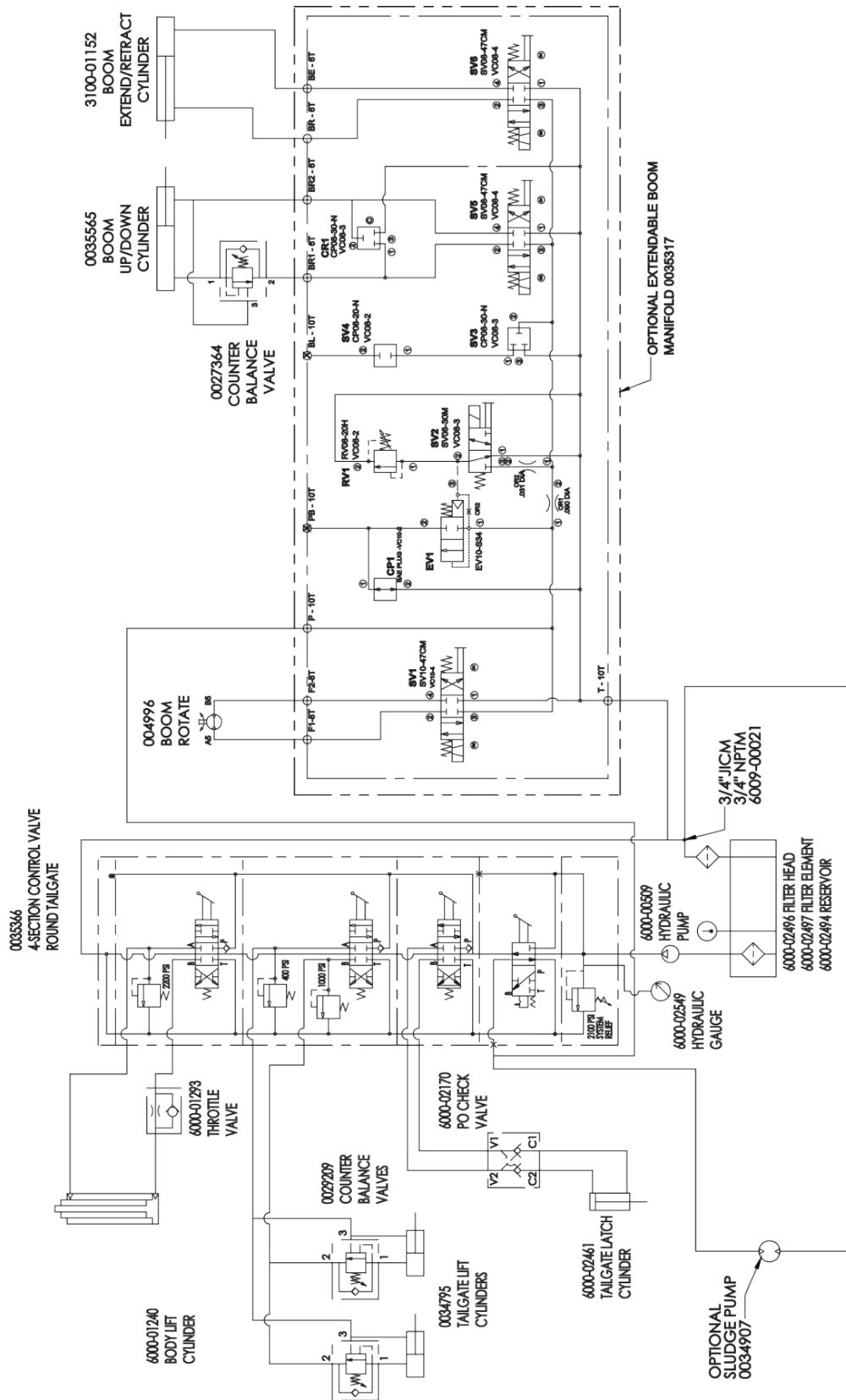

Schematic Supersucker Liquid Ring Water System - 0042508

5

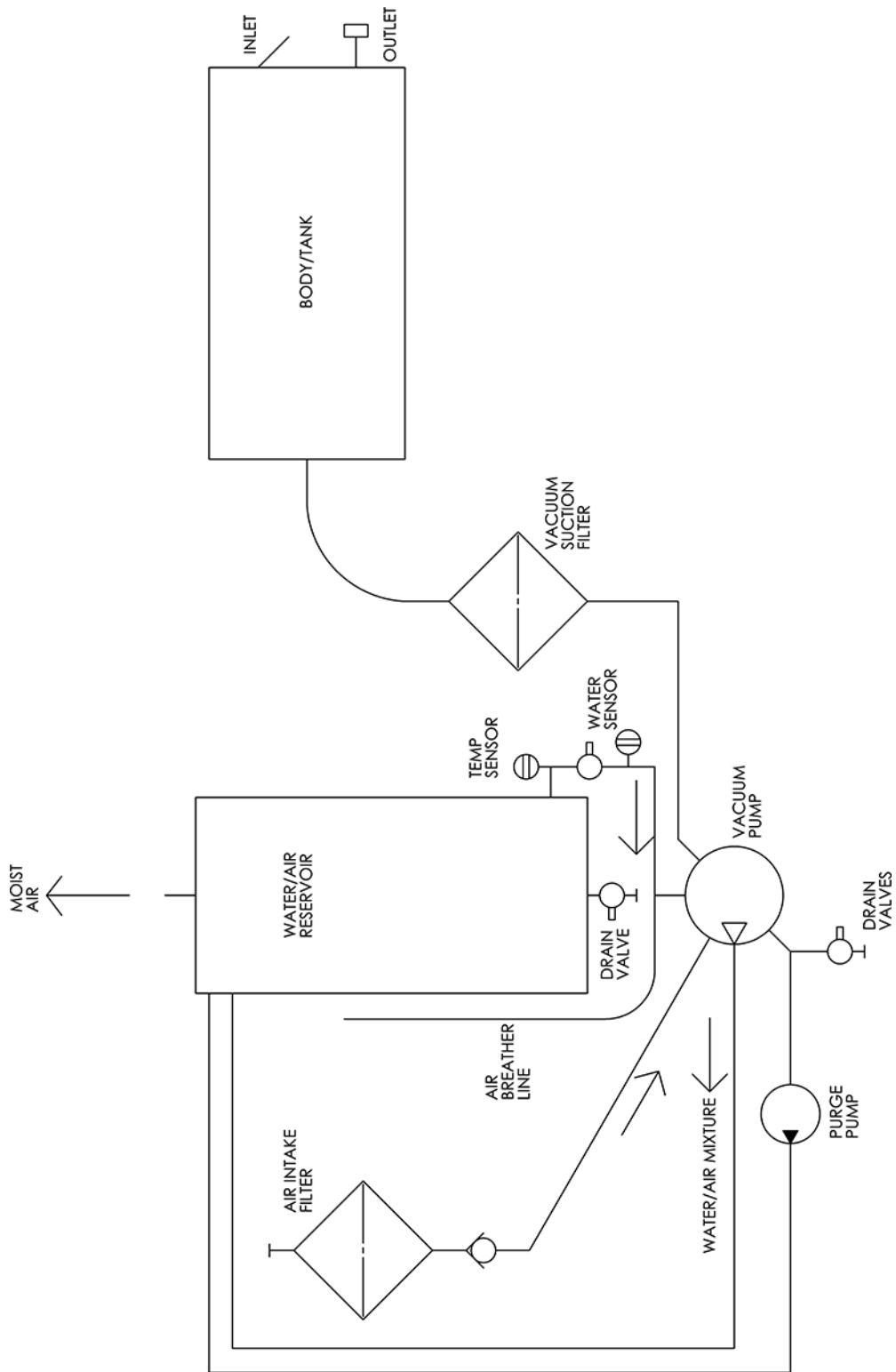

Schematic SS Liquid Ring Transfer Case Hydraulic - 0042518

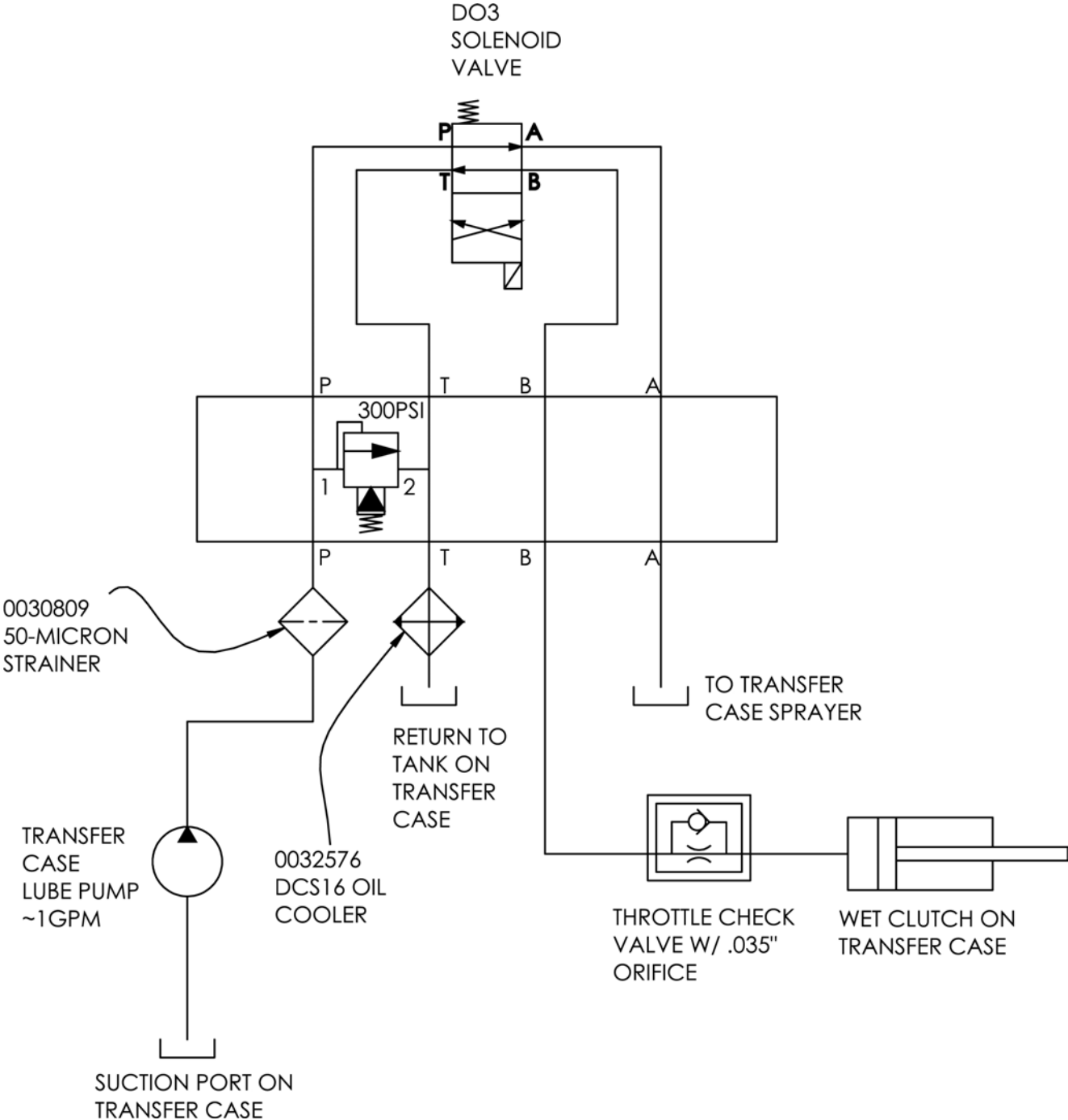

5

Service and Spare Parts

First Year Spare Parts		
QTY	Part Number	Description
60	3000-02109	Filter Bag
60	3000-02200	Filter Cage
3	9300-00116	Hose Assembly
1	8510-00858	Reducer 8" x 6" (Steel)
1	8500-01954P	8" 45 Deg. Rear Port
6	000-00010	Lock Ring Clamp 8" 6
6	3000-00011	Lock Ring Clamp 6"
1	8500-00284	Hose Plug 8"
2	6000-02497	Hydraulic Filter
2	3500-00632	Cleanout Door Gasket
1	9800-00436	Tailgate Latch Roller Kit
1	9000-00564	Tachometer Sensor
2	7300-01764	12" Dump Tube Gasket
6	3500-00001	Flat Coupling Gasket 8"
6	3500-00002	Flat Coupling Gasket 6"
1	8500-01881P	Hinge Assy. Tailgate (Safety)
1	9000-00177	Steel Reducer W/Air Bleeder 8"x 6"

Other Service Parts		
QTY	Part Number	Description
1	3500-00192	Tailgate Gasket
1	8500-01800	Rear Deflector
1	5500-00709	Transfer Case Micro Switch
10	3000-00021	Coupler 6" Female
10	3000-00031	Coupler 6" Male
20	0258-00006	Spiral Clamp 6"
2	8500-01881P	Hinge Assy. Tailgate (Safety)

SERVICE AND SPARE PARTS

Other Service Parts		
QTY	Part Number	Description
1	5500-00494	Tachometer/Hour Meter
1	6000-02499	Hydraulic Filter Gauge
2	6000-00689	Hydraulic Filter Gasket
1	3500-00508	Port Hose 8" x 14' 8" (Boom)
2	3000-00136	Port Hose Clamp 8"
1	3000-02615	Vacuum Break 6"
1	5500-01381	Timer Board, Pulse System
2	6000-01241	Tailgate Lift Cylinder
1	6000-00383	Tailgate Latch Cylinder
1	6000-02286	Vac Relief Solenoid Valve
2	3500-00189	8" Inspection Door Gasket
3	3500-00537	Baghouse / Separator Door Gasket
1	6000-01253	Air Pulse Pilot Valve
1	6000-01895	Diaphragm Valve, Pulse System
1	5500-01145	Gauge, Temperature
1	9000-00563K	Tailgate Safety Pin Kit
1	3500-00454	Make/Break Gasket
1	2000-03158	Replacement Cone Separator
1	3500-00014	Gasket, Vent Door Port
1	6000-01314	Cylinder, Pneumatic Vent Door
1	8500-01622P	Rotating Boom Cannon
1	8500-01245	Cannon End Cover 8" (F)
1	8500-02140	Cannon End Cover 8" x 22° (Barbed)
1	8500-03133P	Cannon End Cover 8" Strait (Barbed)
1	3000-02208	Float Ball 14"
1	8500-01657	Support, Float Ball

6

Index

A

Air Conveyance **2-3**
 Airflow **2-4**
 Arrange for Traffic Control **1-14**

B

Before Performing Service, Repairs, and Maintenance
 on the Equipment **1-33**
 Before Transporting Truck Inspection **1-12**
 Biological Hazards **1-11**

C

Chemical and Biological Hazard Safety **1-11**
 Chemical Waste Hazard **1-11**
 Chemicals and Diesel Engine Exhaust **1-11**
 Confined Space Hazard **1-30**
 Control Valves **3-2**
 Controlling Lower Explosive Level (LEL) **1-26**
 Cooling Air Injection Valve **2-8**
 Crushing Hazards and Prevention Safety **1-7**

D

Debris Body Dumping Safety and Hazard Warnings
1-29
 Debris Body Prop Support **1-7**
 Debris Body Tailgate Props **1-47**
 Decal Location **1-34**
 De-energize and Lockout Procedures **1-32**
 DEF Maintenance **4-2**
 Determine Maximum Turning Speed Before Operating
 on Roads or Uneven Ground **1-13**
 Determine Stopping Characteristics of Truck for
 Transporting Braking Tests **1-13**
 Dust Hazard **1-11**
 Dust Hazard and Explosion Prevention Safety **1-24**

E

Emergency Stop Button Function **1-16**
 Equipment Guards **1-6**
 Equipment Specifications **2-1**

F

Fire Extinguisher **1-15**

G

General Hazards and Prevention Safety **1-5**
 General Safety Instructions and Practices **1-1**

H

Hazards With Equipment Maintenance **1-33**
 High Dump Operation (Optional) **3-10**
 High-Pressure Fluid Leak Hazards **1-9**
 High-Pressure Water Safety and Hazard Warnings
1-23
 High-Temperature Prevention **1-26**
 Hot Surface **1-6**
 Hydrocarbon Waste Recovery **1-25**

I

Inspect the Job Site **1-15**
 Introduction **2-1**

J

Job Site Safety and Hazard Warnings **1-14**

L

Liquid Ring Control Panel (Optional) **3-9**
 Liquid Ring Error Light **2-8**
 Liquid Ring Transfer Case Oil Strainer **4-5**
 Liquid Ring Vacuum Pump Intercooler Screens **4-5**
 Liquid Ring Vacuum Pump Oil **4-5**
 Liquid Ring Vacuum Pump Operation **2-6**
 Loading Rates **2-11**
 Lubrication and Maintenance General Information **4-1**
 Lubrication Recommendation Chart **4-1**

M

Mechanical Troubleshooting **5-2**
 Mobile Ground Verification (MGV) System (Optional)
3-8

INDEX

Mounting and Dismounting Truck or Equipment **1-6**

N

Never Exceed your Gross Vehicle Weight Rating (GVWR) **1-12**

O

Operating the Remote-Operated Vacuum Relief Valve **1-21**

Operating the T-Type Vacuum Relief Valve **1-19**

Overhead Power Line Tips for Construction Workers Before You Begin Construction Work **1-10**

P

Pedestrian Safety **1-12**

Performing Service, Repairs, Lubrication, and Maintenance **1-33**

Personal Protection Equipment (PPE) **1-3**

Plan for Emergency Services **1-14**

Power Distribution Panel **3-1**

Power Lines/Static Electrical Hazard Warnings **1-10**

Preparation Before Traveling To Worksite **1-48**

Prepare for Working Near Existing Utilities **1-14**

Prepare the Job Site **1-15**

Pre-Start Checklist **1-18**

Preventive Maintenance Instructions **4-1**

Principles of Operation **2-1**

Pure Vacuum **2-3**

R

Rotary Lobe Vacuum Pump Operation **2-5**

S

Safety Shields, Guards, and Safety Devices Inspection **1-33**

Safety Signs **1-6**

Seal Water Contamination **2-8**

Service and Spare Parts **6-1**

Sewer Gas Hazard **1-11**

Sewer Gas Safety and Hazard Warnings **1-30**

Spark and Fire Prevention Safety **1-24, 1-28**

Static Charge Dissipation **1-27**

Suction Line Connections **2-10**

T

Tailgate Prop Support **1-7**

Testing the Remote-Operated Vacuum Relief Valve **1-22**

Testing the T-Type Vacuum Relief Valve **1-20**

The Basic Troubleshooting Process **5-1**

To Help Avoid Injury **1-14**

To Restore Power **1-17**

Transport Safety and Hazards Warnings **1-12**

Trenching Hazards **1-31**

Trip and Fall Prevention Safety **1-8**

Troubleshooting Overview **5-1**

Truck Tip Over **1-7**

U

Unlocking the Tailgate Props and Raising the Debris Body Tailgate **3-4**

V

Vacuum Equipment Operation Safety and Hazard Warnings **1-16**

Vacuum Operation **1-18**

Vacuum Operation Safety **1-17**

Vacuum Relief Valves **2-9**

Vacuum Relief Valve Safety **1-19**

Vacuum Relief Valves **1-19**

Vacuum System **2-3**

Visibility Conditions When Operating **1-6, 1-15**

Visual Attention Safety **1-2**

W

Water System **2-9**

When Transporting Equipment **1-13**

When Using Pressurized Air or Water **1-4**

Working with Tools and Equipment **1-10**

Limited Factory Warranty

Subject to the terms and conditions below, Super Products warrants to its original purchaser or an approved transferee ("Purchaser") that new equipment sold after the effective date of this limited warranty is free of defects in material or workmanship at the time it was shipped from Super Products for a period of 12 months from the following: (i) the shipment date or 60 days from the invoice date (whichever occurs first) if the equipment is sold directly to the Purchaser by Super Products or (ii) the in service date if the equipment is sold to the Purchaser by an authorized dealer ("Warranty Period Start Date"), provided the equipment is used in a normal and reasonable manner and in accordance with all operating instructions. Super Products agrees, at its sole election, to either repair or replace (inclusive of labor if through a service center authorized by Super Products) any defective parts and components incorporated in or included with the equipment, not to include any chassis manufactured by third party manufacturers. This Limited Factory Warranty is subject to those terms, conditions, limitations, and exclusions described herein and in Super Products' Warranty Policy in effect on the Warranty Period Start Date. Super Products will not honor warranty claims that have not been filed within thirty (30) days of the repair of the defect or failure that initiated such warranty claim and have not been completed in accordance with Super Products' Warranty Policy.

As part of this Limited Factory Warranty, Super Products provides the following warranties for the designated components:

- 10 Years from the Warranty Period Start Date on the debris body (from defects in material or workmanship), including parts and labor, but any claims submitted after the first 12 months of the warranty period must be preapproved by Super Products.
- 10 Years from the Warranty Period Start Date on the poly water tanks (from defects in material or workmanship), including parts and labor in first 12 months of warranty period, but any claims submitted after the first 12 months of the warranty period must be preapproved by Super Products (after first 12 months only parts are included).
- 3 Years from the Warranty Period Start Date on Super Products' single-piston water pump (from defects in material or workmanship), including parts and labor, but any claims submitted after the first 12 months of the warranty period must be preapproved by Super Products.
- 90 days from the Warranty Period Start Date on loose hardware, fitting and hose leaks, and loose electrical connections (from defects in material and workmanship).

Super Products does not provide any express or implied warranty for the following components, parts, and services; however, Super Products in its sole discretion may choose to repair or replace any such components and parts or perform any such services:

- Any major components of the equipment that Super Products used in manufacturing or assembling the equipment manufactured by a third party manufacturer (including, but not limited to, truck engines or any component of the chassis). Super Products assigns to the Purchaser any applicable warranty offered by the manufacturer of such components.
- Normal wear parts, including but not limited to, valves, gaskets, light bulbs, filters, oils and fluids.
- Consumable items, including but not limited to, vacuum hose, sewer hose, nozzles, and vacuum tubes.
- Normal adjustments and maintenance services.

This Limited Factory Warranty does not cover any damage to nonfunctioning or malfunctioning of the equipment, or any components or parts comprising the equipment, due to: (a) any alteration, substitution, misuse or abuse by the Purchaser or its agents; (b) their non-compliance with any operator's manual, maintenance manual or warning published by Super Products or the component manufacturer and issued to the Purchaser; or (c) their non-compliance with the general standard of reasonable care.

OTHER THAN AS EXPRESSLY STATED HEREIN, TO THE EXTENT ALLOWED BY LAW, SUPER PRODUCTS MAKES NO OTHER WARRANTY, EXPRESS OR IMPLIED, AND MAKES NO WARRANTY OF MERCHANTABILITY OR FITNESS FOR ANY PARTICULAR PURPOSE. SUPER PRODUCTS MAKES NO REPRESENTATIONS OR PROMISES, AND PURCHASER IS NOT RELYING UPON ANY ORAL OR WRITTEN REPRESENTATIONS OR PROMISES, REGARDING ANY PERFORMANCE CHARACTERISTICS OR CAPABILITIES OF THE EQUIPMENT OR THE COMPONENTS THEREOF (INCLUDING, WITHOUT LIMITATION, THE INTEGRATION OF SUCH COMPONENTS OR THE COMBINATION IN WHICH SUCH COMPONENTS MAY BE USED), EXCEPT AS EXPRESSLY STATED IN THE DESCRIPTION OF THE EQUIPMENT CONTAINED IN THE ACKNOWLEDGMENT OR OTHER WRITTEN DESCRIPTIONS PROVIDED BY SUPER PRODUCTS.

SUPER PRODUCTS' MAXIMUM LIABILITY SHALL NOT EXCEED AND PURCHASER'S ENTIRE AND EXCLUSIVE REMEDY IS LIMITED TO EITHER (A) REPAIR OR REPLACEMENT OF THE DEFECTIVE EQUIPMENT, OR AT SUPER PRODUCTS' SOLE OPTION (B) RETURN OF THE EQUIPMENT AND REFUND OF THE PURCHASE PRICE. IN NO EVENT SHALL SUPER PRODUCTS BE LIABLE FOR ANY SPECIAL, INDIRECT, INCIDENTAL OR CONSEQUENTIAL DAMAGES OF ANY KIND ARISING IN CONNECTION WITH OR OUT OF THE EQUIPMENT AND THAT SUPER PRODUCTS' LIABILITY, WHETHER IN CONTRACT, TORT, UNDER ANY WARRANTY OR OTHERWISE SHALL NOT EXCEED THE RETURN OF THE AMOUNT OF THE PURCHASE PRICE PAID BY PURCHASER, WHICH AMOUNT MAY BE REDUCED DUE TO DEPRECIATION AND DAMAGE BEYOND NORMAL WEAR AND TEAR. PURCHASER UNDERSTANDS THAT THE LIMITATION OF SUPER PRODUCTS' LIABILITY RELATING TO THE EQUIPMENT IS A MATERIAL TERM OF THE PARTIES' TRANSACTION.

This Limited Factory Warranty is not transferable without the prior written approval of Super Products.

NO ACTION ARISING OUT OF ANY CLAIMED BREACH OF THIS LIMITED FACTORY WARRANTY OR TRANSACTIONS UNDER THIS LIMITED FACTORY WARRANTY MAY BE BROUGHT MORE THAN TWO (2) YEARS AFTER THE CAUSE OF ACTION HAS OCCURRED.



130 W Boxhorn Drive, Mukwonago, WI 53149 • P: 800.837.9711 • www.superproducts.com